

See discussions, stats, and author profiles for this publication at: <https://www.researchgate.net/publication/229000611>

# A New Visual Basic Based Control Strategy of Hybrid Step Motors For Educational and Industrial Applications

Article · January 2007

CITATIONS

0

READS

106

2 authors:



**Durmus Uygun**

Aegean Dynamics Inc.Co.

31 PUBLICATIONS 134 CITATIONS

[SEE PROFILE](#)



**M. Caner Akuner**

Marmara University

42 PUBLICATIONS 84 CITATIONS

[SEE PROFILE](#)

Some of the authors of this publication are also working on these related projects:



Design, implementation, and application of 150-degree commutation VSI to improve speed range of sensored BLDC motor [View project](#)



Design and Implementation of 4 kW Contra-Rotary Permanent Magnet Brushless Direct Drive Thruster Motor for Underwater Research Systems [View project](#)

# A New Visual Basic Based Control Strategy of Hybrid Step Motors For Educational and Industrial Applications

DURMUŞ UYGUN\*, CANER AKÜNER\*\*

\*Bozok University, Akdagmadeni Technical Vocational School of Higher Education  
Electricity Programme, Akdagmadeni, 66300 Yozgat, TURKIYE.

\*\*Marmara University, Technical Education Faculty, Department of Electricity Education  
Goztepe, 34772 Istanbul, TURKIYE.

*Abstract:* - This paper is carried out to enhance a useful computer program for digitally controlled hybrid step motors (HSM); application of computer program to perform the analysis of operation values for HSM such as number of steps, angular way, motor speed; and advanced use of that digitally programmed HSM in industrial applications. This program provides an algorithm including the command strategy of parallel ports for the control of HSM; presents a user-friendly software package developed in Visual Basic and enables to combine numerical computations and graphical illustrations. This advanced package can be used for the other motor control systems with a little change in the source of the program in any educational (technical education, electricity-electronics and computer engineering) and industrial application areas.

*Key-Words:* - Hybrid step motors; Visual basic; Digital control; Parallel port.

## 1 Introduction

The main task of the application is to generate a operation method for the hybrid step motor using a Windows application named as Visual Basic 6.0 programming language [5], [6], and to send appropriate commands through parallel port so as to move the motor from a special initial position to a destination point within a known angular position and movement.

The control of electric motors is a traditional control problem which has attracted new interests in the control theory community [2]. Along with the evolution of the control technology, using of hybrid systems has attracted an increasing attention in the industry. Within this idea; hybrid step motors have been developed and started to be used in all fields that the technology has increased.

Hybrid step motors (HSM) share the operating principles of both permanent magnet (PM) and variable reluctance (VR) stepping motors. The rotor for a hybrid stepping motor is multitoothed, like the variable reluctance motor, and contains an axially magnetized concentric magnet around its shaft. The teeth on the rotor provide a path which helps guide the magnetic flux to preferred locations in the air gap. The magnetic concentric magnet increases the detent, holding and dynamic torque characteristics of the motor as described in [3]. As known; all step motors operates in the same way. When they are exposed to have logic or electrical pulse signals input in order, the shaft or spindle of the hybrid step motor rotates in discrete step increments. The sequence of the applied pulses is directly related to the direction of motor shaft rotation. The speed of the motor shaft rotation is directly related to the frequency

of the input pulses and the length of rotation is directly related to the number of input pulses applied.

## 2 Hybrid Step Motor Control System Hardware

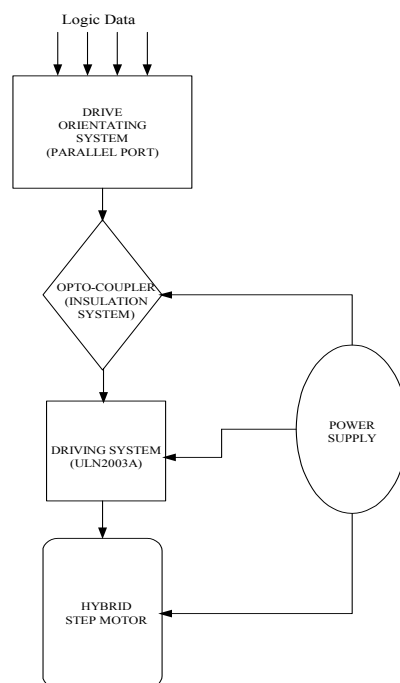

Fig. 1. The interaction between Visual package and hybrid step motor via PC's parallel port and the process of data transmitting

There are several ways to apply input pulses for driving HSM. In this paper; the readout and control systems we have developed share the basics of widespread standard PC's parallel port interface [4]. As known; the parallel port is the simplest PC interface. The aim of using parallel port is to produce a voltage level of 5 V according to program written in Visual Basic, C++, Fortran, etc. The flow diagram in fig.1 explains data transferring system that we have used for control mechanism through parallel port. It is possible to program all functions of the system in the algorithm we have arranged in Visual package. The most important block in the system is ULN2003A driving system which is a versatile device that are useful for controlling a wide range of loads including solenoids, relays, any kinds of DC motors, LED displays, filament lamps, thermal print-heads and high power buffers. In our paper; that driving block has been used to carry commands which were sent through parallel port and move the motor from an initial position by means of these commands.

As a whole; general block diagram of the system can be shown as it is illustrated below:

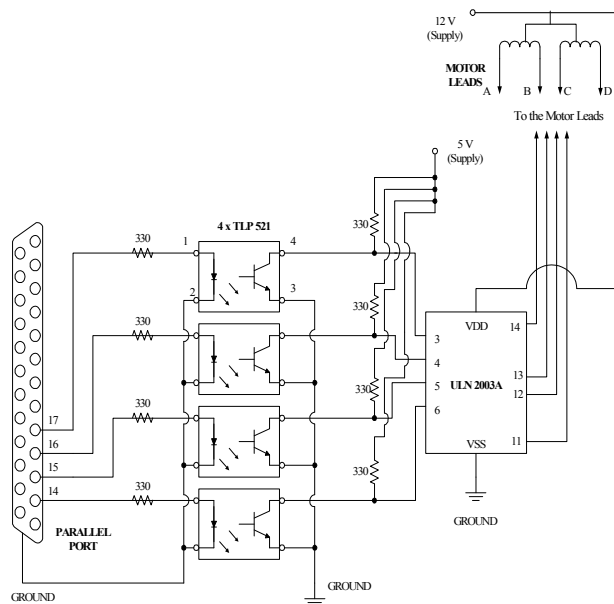

Fig. 2. General block diagram of the designed system

General block diagram of the system clearly shows the interaction between hybrid step motor and parallel port control interface; and the system can be controlled through user-friendly menu driven interface forms by Visual package.

### 3 Visual Basic and Hybrid Step Motor Control Package (HSMCP)

Microsoft Visual Basic is designed for graphical user interface (GUI) programming [1]. We have chosen

Visual Basic 6.0 as the programming language due to the convenience it provides in handling images and the graphic toolkit supplied by the language to be used in performing the simulations and screen representations for the displacement tracking.

The Visual Basic (VB) interface developed provides displays for profiles of system variables which include motor speed, angular way/angular position and number of steps; and also, displays graphs indicating motor speed relating to time, angular way relating to time and number of steps and design results are generated simultaneously. To develop a control unit like that, the main task of the application has been to generate a control interface for the motor. It is possible to appreciate that the main problem may be divided into two sub-problems; one of them should generate a flowing diagram as mentioned in previous section and prepare the application to send instructions to the system that will be controlled. The other should deal with the parallel port, its programming, event notifications, data sending, error handling, obtaining operation values of the HSM to hold them in tables and draw graphs about these operation values.

#### 3.1 Features of the Computer Package

Development of a comprehensive computer package seeks ease of use, improveability, and accuracy of the results. Features of the VB computer package include the following:

- Ability to select and adjust the design and parameters used in the calculations.
- The computer codes check and limit the value of input and output parameters within practical ranges.
- Several displays are used to present the design and operation results. These displays include performance results, profiles, flow diagram, and operation tables and graphs.
- Availability of help and tutorial files.
- Capability to print forms and results of data files.
- Capability for handling of various errors.

#### 3.2 Main Control Panel and Features

By following the installation process given in this section; when the hybrid step motor control package which was developed by using Visual Basic 6.0 programming language and used to control system through parallel port communication interface is first activated, the following view of main program appears on the screen:

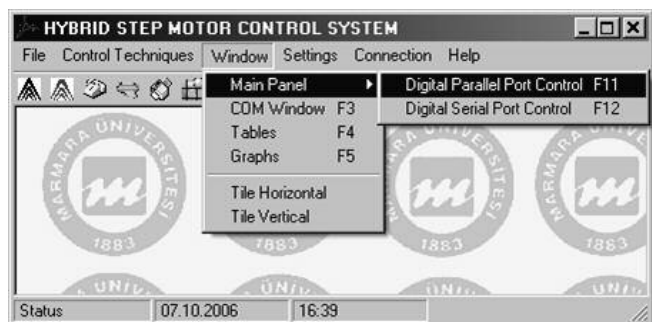

Fig.3. Start-up view of the program and menus

Fig. 3 shows the start-up view of the computer package, which includes help files, process selection, adjustment of input design data, view of various displays, and print of forms or operation tables and graphs.

Considering that the Visual Basic 6.0 is not installed on the target system, all the necessary support files used by the motor control package are added into the installation file (i.e., Setup file) by using the Package&Deployment Wizard which is one of Microsoft Visual Basic 6.0 tools. The program and its associated files are installed into the directory of "C:\Program Files\HSMCP" during the installation process. However, the user-specified directory is accepted by the setup program. The Package&Deployment Wizard has created uninstalling application from the target computer by using the following "Start » Programs » HSMCP » Uninstall HSMCP" options. However, motor control package can be uninstalled by selecting first "Add/Remove Programs" option in the Windows control panel.

In the control program; there are several menus and submenus. But the most important one is the "Window" menu because of the fact that it is possible to reach all control submenus and control panels. Before explaining operation features of the submenus under "window menu", it would be better to clarify the "file", "control techniques", "settings", "connection" and "help" menus.

- **File:** includes "print tables", "print graphs" and "exit" submenus. It is possible to print all desired tables and graphs by means of these submenus. And "exit" provides to quit system.

- **Control techniques:** consists of "Digital parallel port control sys" and "Digital serial port control sys" submenus which allows to enter these systems. But in this paper; only parallel port controlled system has been represented.

- **Connection:** gives facility to access a few important web sites used during the development of the work.

- **Help:** contains a help software developed HTML Help Workshop and an "About Software" form.

## 4 Parallel Port Controlled System Representation

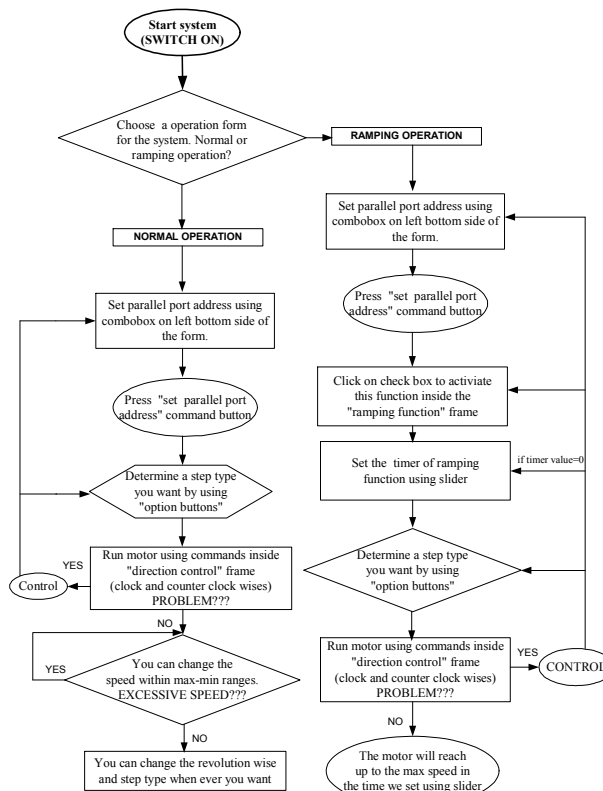

Fig.4. Flow diagram of parallel port controlled system

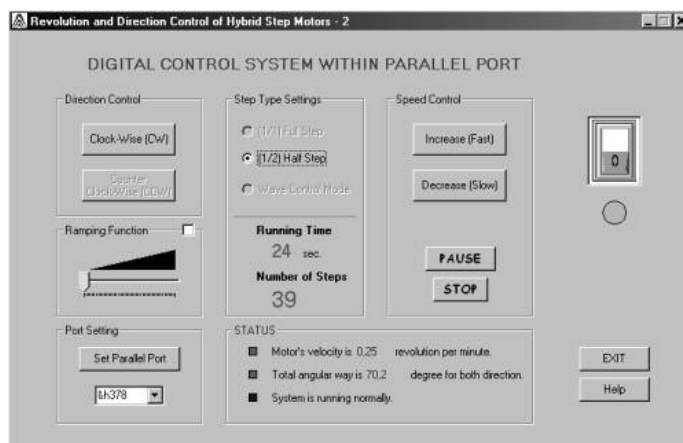

Fig.5. Parallel port controlled system and parameters

Here, all the three tasks are solved together. Based upon the proposed algorithm; the computer package has been exclusively used for the purpose of obtaining the motor speed, revolution wise and angular way.

As seen in Fig.5; the system consists of six different control and determination frames. According to the directions of flow diagram (Fig.4); the system frames should be used in that order given below after the system has been activated with ON/OFF command

button and the operation method (normal or ramping) has been determined:

a) *Port Setting*: After the system has been activated, the first to do is to set parallel port address by using the combobox given in “port setting” frame. After the address is chosen, the “set parallel port” command must be clicked. If not, the error message illustrated in Fig.6 appears on the screen.



Fig.6. System set error

b) *Step Type Settings*: By using this frame; full, half or wave step control modes can be selected.

c) *Direction Control*: After the port address and step type of the motor has been determined, the revolution wise (clock or counter-clock wise) is selected and the motor is driven using this frame.

d) *Speed Control*: While the motor is running, the motor’s velocity can be changed within a range using this module; as well as the step type or the revolution wise are changed. If the motor speed is exceeded, the following error message appears on the screen:



Fig.7. System excess speed error

e) *Ramping Function*: This function is another operation method to drive HSM in the paper implemented. To use this function; after the port address has been determined, the check box given in the frame is signed and ramping scale is set considering operation or maximum ramping time. Because when this function is activated, the motor reaches up to the maximum speed value within selected range by changing the timer.

f) *STATUS*; is the frame that all numerical expressions take part in. Motor’s velocity as rpm, total angular way as degree, the operation mode of the motor (slow mode, average speed mode and fast mode) can be observed here.

## 5 Control System’s Tables and Graphs

The suitability of the proposed algorithm and its associated package has been ascertained by the

application to a designed system shown in Fig.2. The proposed algorithm and the package developed are found to be technically sound. The application procedure and steps have been presented in previous sections of the paper.

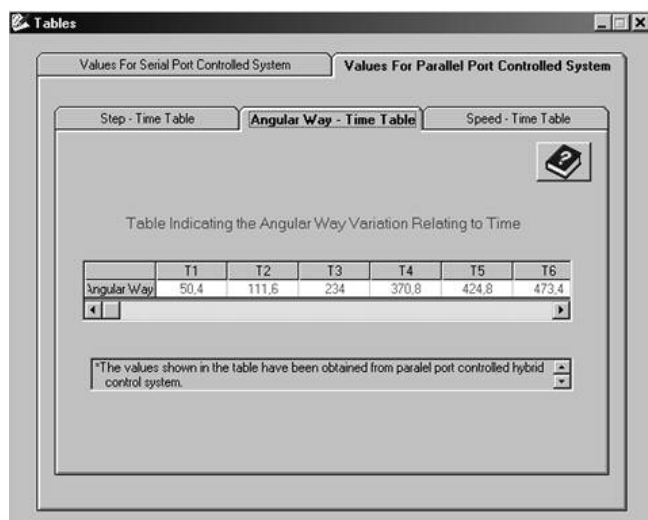

Fig.8. Table values of the system

One of the best solutions of the paper is to watch the graphs of motor speed, angular way and number of steps relating to time. First of all; all the values of these magnitudes for both parallel and serial port controlled systems are collected in a table form as shown in Fig.8.

The angular way-time table is given as an example here. To obtain these values; the indications in parallel port controlled system control panel such like number of steps, angular way and motor’s velocity labels have been used. On this table; the symbols T1, T2, ....., T10 are operation periods of the motor. The interval time between T1 and T2 or T5 and T6 are the same and 10 seconds each. That means; to determine a full operation period for the HSM, an interval of 100 seconds is needed and obtained here. As an example, for that full operation period given above; the motor has taken a way of 50,4° in the first period of ten seconds and 370,8 ° in forty seconds and so on.

At the same time those values are automatically written into tables’ lines, the graphs of the system are successfully drawn into “graphs” form as shown in Fig.9, Fig.10 and Fig.11.

As seen on the graphs; the horizontal coordinate (R1, R2, ..., R10 indications) presents operation periods as interval time (10 seconds each); and the vertical coordinate presents angular way taken by the motor as degree, number of steps relating to time and motor speed as rotation/minute (rpm). Moreover, it is possible to see maximum, minimum and average “angular way” expressions drawn with dashed lines on the graph in Fig.9, and the same for “motor speed” graph in Fig.10 and “number of steps” graph in Fig.11, too.

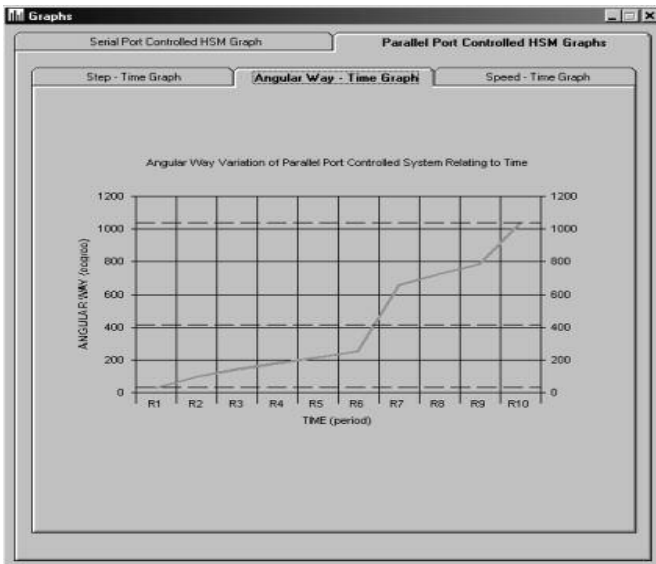

Fig.9. “Angular way” graph relating to time



Fig.10. “Number of steps” graph relating to time

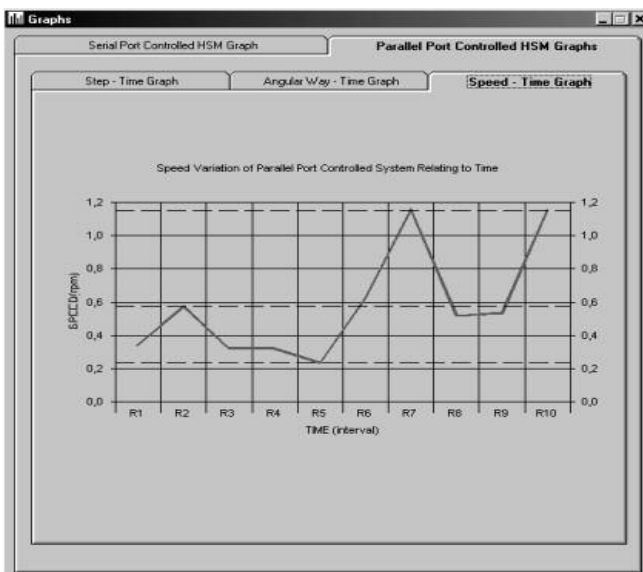

Fig.11. “Motor speed” graph relating to time

## 6 Other Features of The Sytem

This developed package which is useful for the study of digital controlling of hybrid step motors includes many advantages in use different from that were expressed in previous sections.

One of the most practical specifications is to provide an easy use of Help Form for control package developed by using HTML Help Workshop consisting of an online Help Viewer, related help components, and help authoring tools. This help file will guide you to learn a lot about computer package and features.

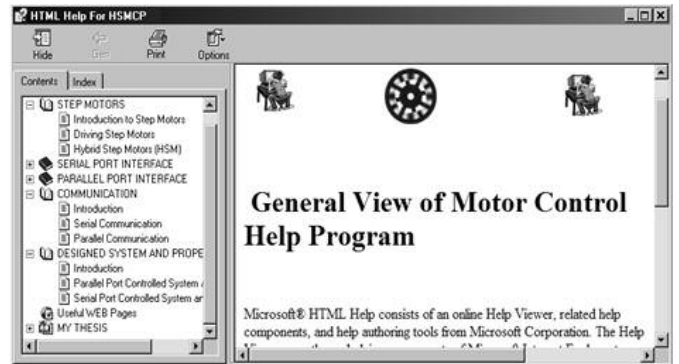

Fig.12. HTML Help for HSMCP

## 7 Conclusion

This paper has discussed the application of digitally controlled hybrid step motors through parallel ports to achieve obtaining operation values of HSM to simulate them later. For a beginner, to start to use developed package; basic concept with parallel port controlled system algorithm based on a conventional approach has been presented.

The beginners should use HTML Help for hybrid step motor control package in order to practice in the best way possible and gain confidence. The package has been tested on the system illustrated in Fig.2 and provides an ease of use. The operation method for HSM has been generated using Visual Basic 6.0 programming language which is user-friendly and useful for the study of digitally controlled hybrid step motors. And also; this advanced and developed package can be used for the other motor control systems with a little change in the source program; and thought to be practical for technical education or electrical engineering courses in deed.

## References

- [1] Dukovic, J.M.; Joyce, D.T: “An Evaluation of Object-Based Programming with Visual Basic”, Shared Medical Systems Corporation, Malvern, PA and Villanova University, Villanova, PA, 1995.

- [2] Chen, D.; and Paden, B.: “Adaptive Linearization of Hybrid Step Motors: Stability Analysis”, Department of Mechanical and Environmental Engineering, University of California, Santa Barbara, Santa Barbara, *IEEE Trans. On Automatic Control*, vol. 38, no. 6, June. 1993.
- [3] Jones, D.W.: “Stepping Motor Fundamentals”, *Microchip Technology Inc.*, AN907, University of Iowa, United States, 2004.
- [4] Axelson, J.: “Parallel Port Complete: Programming, Interfacing and Using the PC’s Parallel Printer Port”, *Resource; Bk&Disk Edition*, 1997.
- [5] Peter Wright’s, *Beginning Visual Basic 6*, 1998.
- [6] Eliason & Malarkey, *Visual Basic 6.0, Environment, Programming & Application*, 1999.