

# Recent Advances on Convolutional Architectures in Medical Applications: Classical or Quantum?

Saif Al-jumaili  
Electrical and Computer Engineering  
Altinbas University  
Istanbul, Turkey  
saif.aljumaili@ogr.altinbas.edu.tr  
saifabdalrhman@gmail.com

Ahmed Al-jumaili  
College of Medical Sciences  
Techniques  
University of Mashreq  
Baghdad, Iraq  
ahmed.aljumaili@my.jcu.edu.au  
Ahmed.al-jumaili@uom.edu.iq

Salam Alyassri  
Electrical and Computer Engineering  
Altinbas University  
Istanbul, Turkey  
salamyassir@gmail.com

Adil Deniz Duru  
Neuroscience and Psychology Research  
in Sports Lab  
Marmara University  
Istanbul, Turkey  
deniz.duru@marmara.edu.tr

Osman Nuri UÇAN  
Electrical and computer engineering  
Altinbas University  
Istanbul, Turkey  
osman.ucan@altinbas.edu.tr

**Abstract**—Deep learning is one of the most significant advances in AI (AI). It is used in a variety of fields due to it has the ability to solve problems that cannot be handled by traditional technologies. The optimization of deep learning relevant to medical images is one of the most important recent advances in image analysis. Several developments have been done on Convolutional Neural Networks to achieve optimal accuracy and increase the learning speed. However, in this paper, we discuss the most recent innovations in convolutional neural networks within Classical method and Quantum method. We briefly provide a snapshot about the architecture, improvements, and principles of both (Classical and Quantum).

**Keywords**—Quantum Convolutional Neural Networks, Convolutional Neural Networks, Classification, Medical images, Deep learning

## I. INTRODUCTION

Deep learning is one of the most important developments in the modern era. It used in different fields such as speech analysis [1, 2], speech recognition, Image restoration, bioinformatics, Image Processing [3], Object Detection, Video Processing [4], computer vision [5, 6], and natural language processing (NLP) [7]. Deep learning mimics how the human brain functions, where the keystone of deep learning designs is the amount of layers employed in the neural network, which is analogous to how the human brain processes information. Many types of deep learning models provide aid for healthcare sector due to the ability to classify the images with high accuracy and reduce time-consumption. Particularly in the medical sector, it is used with various imaging modalities such as Histology [8], Computer Tomography (CT) [9], Microscopy [10, 11], positron emission tomography (PET), X-Ray [12], Ultrasound [13], Single-photon emission computed tomography (SPECT), and Magnetic resonance imaging (MRI) [14, 15].

The primary goal of medical images is to effectively diagnose diseases by clinicians and radiologists. Where these sorts of graphics serve an important part in explaining functional details about various bodily organs for illness diagnosis. At present with increase types of medical images that provide information for clinicals, the most convenient methods are those that have the ability to analyze these types of images and provide high accuracy results [9]. There are numerous algorithms created for the classification of medical pictures in cutting-edge deep learning, such as Convolutional

Neural Networks (CNN) [16], and Quantum convolutional neural networks (QCNN) [17]. A neural network's primary function is a multi-layer hierarchical network that is separated into two main parts: feature extraction and classification. Because of its efficacy on the outcomes, the extraction of relevant knowledge from pictures is significant, and the recovered features will subsequently be utilized as input to classifiers in order to classify them for the groups. Indeed, Many evaluation metrics, including accuracy, F-measure, precision, recall, sensitivity, and specificity, are used to assess the effectiveness of deep learning techniques and it is primarily desired that these measures provide great results for medical image analysis [13].

In general, there are multiple platforms used for classification in deep learning such as Caffe [18], TensorFlow [19], Theano [20], Keras, Torch, PennyLane [21], Qiskit [22], Azure Quantum, TensorFlow Quantum [23], Xanadu, Rigetti [24], Matlab, and Q# to name a few. In deep learning, the most of these platforms are an open-source code, which is available in GitHub for researchers in order to make a test on the medical images. Till now, the challenges remain to elect the best architecture to be a milestone for several different types of medical images.

In this paper. we will elaborate review of the recent techniques used for the classification of medical images, that rely on deep convolutional architecture. Moreover, the study provided the present CNN architectures for both (Classical and Quantum). And provide a guide for the researchers that used convolutional architectures with different modalities. Finally, We provide the latest papers published using medical images.

## II. ARCHITECTURAL EVOLUTION OF DEEP CNNs

Medical images have different types of modalities that can provide a piece of useful information about the human body. The main objective of medical images is to provide visual information about the case of the patient for radiologists and clinicians, which can help them to diagnose and remedy more efficient. In medical images, various types of modalities are used such as, PET, MRI, CT, X-ray, ultrasound, and as well as many other hybrid methods used [25]. These many sorts of medical photographs serve an important role in detecting the functionality of human bodily organs, which can assist in diagnosis and therapy. [26]. Figure 1 appears the typology of the most popular image patterns used in deep learning.

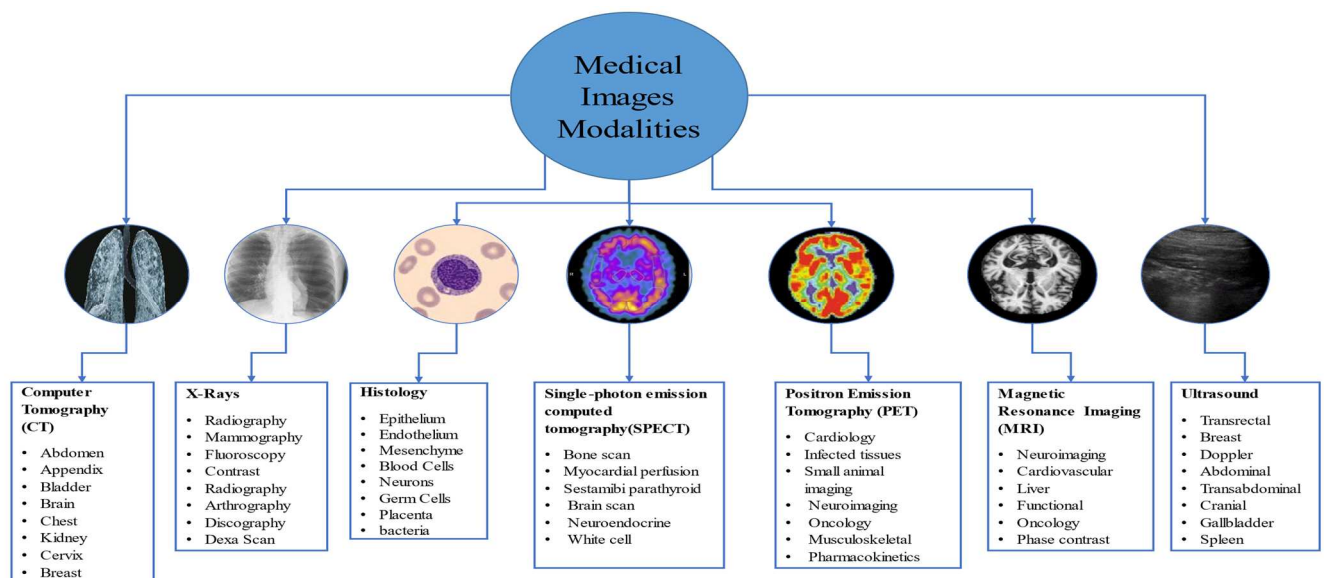

Fig. 1 Typology of the most common image patterns used in deep learning

### III. CONVOLUTIONAL NEURAL NETWORKS

CNN is considered one of the most widespread approach techniques used for classification in Deep learning. CNN show distinguished results recently in different fields. Convolutional layer, Batch normalization, Pooling Layer, Dropout, Activation Function, Fully Connected Layer, and other layers are commonly employed in the construction of a CNN model. The basic approach of CNN is based on inheriting information between layers, which means that the next layer depends on the information extracted from the previous layer. And it has the ability to discriminate the important features, this is why it is exploited capability of classification the medical images.

Many improvements have been made based on the architecture of CNN, the improvement has been done on structural reformulation, parameter optimization, regularization.. etc. Different modifications have been happed on the CNN architectures, Which can be classified into seven major kinds namely, feature-map exploitation, depth, spatial exploitation, attention-based CNNs, multi-path, width, and channel boosting, where the Figure 2 shows the taxonomy of the main seven kinds and they are explained as following:

#### A. Spatial exploitation

In CNN, there are many types of parameters that can effect on performance, such as biases, weights, number of layers and neurons, activation function, pitch, filter size, learning rate, etc. And various types of correlation levels can be examined through filter size, which has an effect on the granularity. Different filter sizes include varying levels of granularity; Usually, a small filter size used for extract information for fine-grained. Whereas a large size filter used for coarse-grained. Thus, in the early 2000s, many CNNs use spatial filters due to the effect on the relationship between spatial filters and network learning, which ultimately improves the model's performance.

#### B. Depth

The primary principle underlying deep CNN design is that by using extra mappings (nonlinear) and more complicated feature hierarchies, to make the network successfully achieves

the target function. For supervised training, depth is a significant parameter for the network, where the deep models can provide a more effective compared to the shallow models. this architecture proposed by Bengio and Delalleau postulated in 2011, makes the CNN model deeper which improves the computational for more effective for complex procedures. In the ILSVRC-2014 competition, VGG and Inception showed the best results, confirming that depth is a crucial parameter for the control learning network.

#### C. Multiple Paths

Deep CNNs are frequently effective at difficult tasks. It also occasionally struggles with performance deterioration, explosion difficulties, or gradient disappearing, which may happen due to increasing the depth of the CNN network. Where the vanishing gradient effect on the network by increasing error for both testing and training. to avoid this problem multi-path or cross-layer is proposed, which allows for the tailored flow of information between levels.

#### D. Feature-Map Exploitation

CNN has the ability to classify different tasks due to its capability for automatic feature extraction and hierarchical learning, which is considered the most important features. With a heavy number of features that are extracted, CNN selects features dynamically by adjusting the weight of kernels ( or mask), which means different types of steps are performed in order to get the final relevant features. While excessive features effect on the CNN model by leading it to get over-fitting, this implies that feature selection techniques have a substantial impact on network generalization.

#### E. Multi-Connection

In 2019, Kawaguchi prosed a network that is based on width, which is important for network learning. The network that has ReLU activation functions should be wide enough to keep a universal approximation property. The failure of multiple layers to learn important characteristics is a serious concern with deep neural network topologies. To solve this challenge, the research focus shifted from deep and narrow designs to broad and thin architectures.

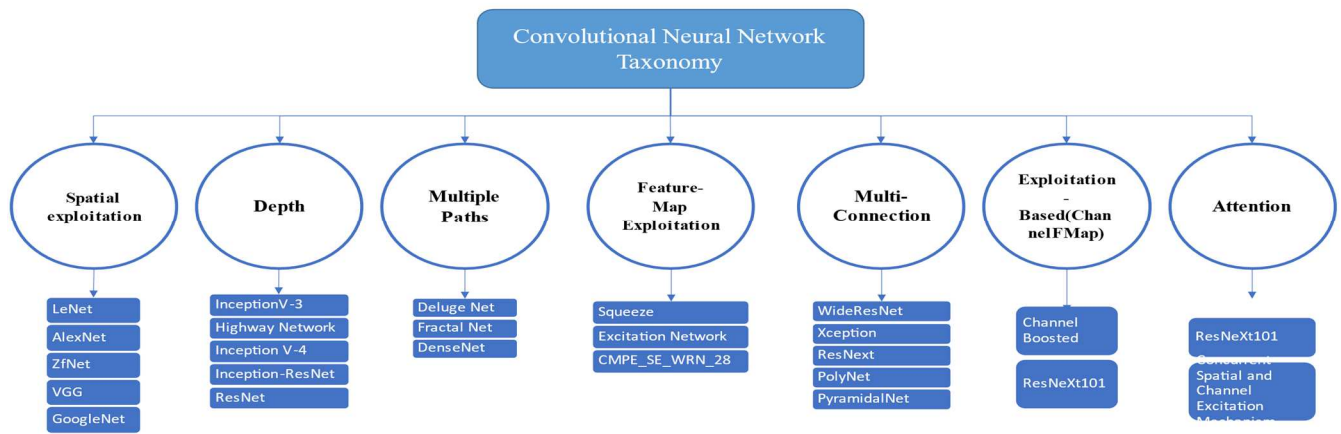

Fig. 2 Taxonomy of the main kinds

### F. Exploitation-Based (ChannelFMap)

CNN has sparked a lot of attention in computer vision issues due to its ability to do hierarchical learning and automated feature extraction [4]. Feature selection has a significant influence on classification performance. Furthermore, multiple feature extraction steps are used in CNN to mine diverse kinds of features. Some feature maps have modicum or no value in object discrimination. Massive feature sets might insert noise into the network, leading it to overfitting. The Feature-Map (ChannelFMap) are commonly used interchangeably in the literature.

### G. Attention

This method concentrates on particular areas and understands several interpretations of things at a single location, therefore increasing visual structure capture. RNN and LSTM have similar interpretations. Attention modules are utilized as a progressive feature in both RNN and LSTM networks. Several studies use the concept of attention in CNNs to improve representation and overcome computational constraints. This attention concept also leads to CNN being intelligent enough to recognize items even in busy backdrops and tough conditions.

Table 1 shows the development of CNNs over the years, as well as the techniques used in order to develop the CNNs. Moreover, which benchmark (image dataset) used for training models.

Table I Summary of CNN architectures

Name	Year	Class	BanchMark
LeNet	1998	Spatial Exploitation	MNIST
AlexNet	2012		ImageNet
ZfNet	2014		ImageNet
VGG	2014		ImageNet
GoogleNet	2015		ImageNet
InceptionV-3	2015	Depth	ImageNet
Inception V-4	2016		ImageNet
Inception ResNet	2016		ImageNet
Highway Network	2015		CIFAR-10
Deluge Net	2016		CIFAR-10
Fractal Net	2016	Multi-path	CIFAR-10
DenseNet	2017		CIFAR-10
WideResNet	2016	Width	CIFAR-10
Xception	2017		ImageNet
PolyNet	2017		ImageNet
PyramidalNet	2017		ImageNet
ResNext	2017		ImageNet
			CIFAR-10

Residual Attention Neural Network	2017	Attention	ImageNet CIFAR-10
Convolutional Block Attention Module (ResNeXt101 (32x4d) + CBAM)	2018		ImageNet
Concurrent Spatial and Channel Excitation Mechanism	2018		MALC, Visceral
Competitive Squeeze and Excitation Network CMPE_SE_WRN_28	2018	Feature-Map	CIFAR-10, CIFAR-100
Squeeze and Excitation Network	2017		ImageNet
Channel Boosted CNN	2018	Channel Boosting	-

### IV. QUANTUM CONVOLUTIONAL NEURAL NETWORKS

The main concept behind the quantum computer is the quantum bit (Qbit), which is the basic component of all approaches to quantum information [17]. The most important properties about the method of processing the values quantum states that can be 0, 1, or both at the same time ( $|0\rangle$  and  $|1\rangle$ ), are called superposition, which is one of the main significant properties that makes the quantum computer so fast. Whereas the sconed properties are entangled, which means combining group Qbit connects between of them and then the results of individual Qbit could be 0 or 1. Whereas the results of Qbit are related with another Qbit [27]. These properties effect on the process speed and make it a billion times more powerful compared to the classical bit (Bit). As shown in Figure 3, the comparison between Qbit and Bit.

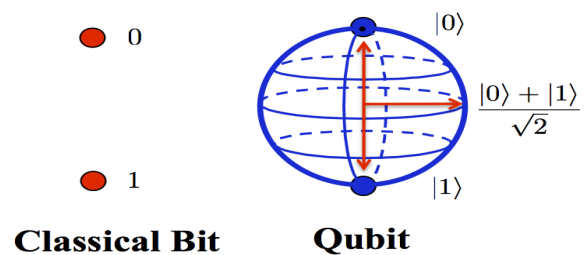

Fig. 3 Comparison between Qbit and Bit [28]

QCNN is similar to CNN in type of work, but the infrastructure is based on the sequence of quantum circuits, that it is the major difference between of them, that used to extract features in quantum state to solve the stubborn problems that cannot handle by classical CNN [29]. Figure 4, demonstrate the differences in their architectures.

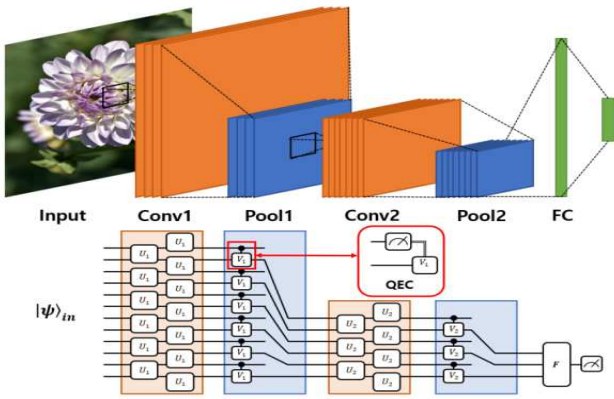

Fig. 4 Comparison between QCNN and CNN [23]

Quantum Convolutional Neural Networks (QCNNs) established (2018) by Cong et al [17]. The construction of QCNNs is inspired by CNNs, Figure 5 show the QCNNs architecture.

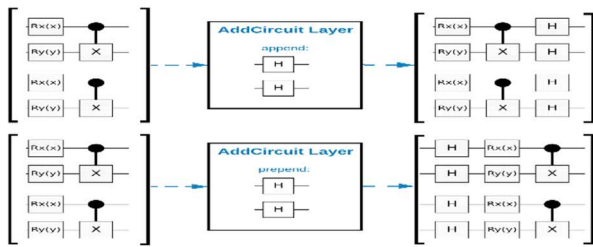

Fig. 5 QCNNs architecture [23]

Convolutions in this context are operations done on adjacent pairs of qubits – they are parameterized unitary rotations, exactly as in a standard variational circuit. Following the convolutions are pooling layers, which are accomplished by measuring a portion of the qubits and utilizing the assessment findings to direct future operations. A fully connected layer's analogue is a multi-qubit operation on the remaining qubits before the final measurement. Every one of these operations parameters are taught throughout training [30].

#### A. QCNN Gates

The method of manipulating qubits, or subatomic particles, to perform calculations utilizing several types of gates such as CNOT, S Gate, SWAP, Hadamard, etc., which are the main architecture of QCNN [31]. Table 2 show the gates that used to building QCNN.

Table II Gates used to build QCNN

Notation	Name	Use
	Pauli X	Logical bitwise NOT
	Hadamard H	Create superposition of the two basis states,
	R1( $\theta$ )	Theta: Double, qubit: Qubit
	S Gate	It completes a quarter-circle around the Bloch sphere.
	CNOT	Permit quantum entanglement between two qubits
	SWAP	Conducts a two-qubit swap
	Toffoli	Flip target quantum bit if both equal 1
	CSWAP	Conditional SWAP

## V. APPLICATIONS OF CNN AND QCNN IN MEDICAL IMAGES

QCNN has been applied in many studies for the classification of diseases and the results showed a clear superiority compared to the traditional method (CNN) in the some fields. This confirms that the development is clear in the possibility of classifying diseases more accurately. Table 3 show the results of the application of CNN and QCNN in the latest studies in the literature. We conclude that Deep learning success in the classification of medical images and obtained high results for both Classical and Quantum.

Table III Recent study using CNN and QCNN

Ref.	Year	Modality	Application	ACC
[32]	2018	CT	Lung Cancer	100
[33]	2017	CT	Lung Cancer	87
[34]	2017	Ultrasonic	Heart	92
[13]	2021	Ultrasound	Covid-19	99
[9]	2022	CT	Covid-19	98.2
[35]	2020	X-ray	Covid-19	96
[36]	2020	X-ray	Covid-19	95.72
[37]	2020	X-ray	Covid-19	98
[38]	2020	X-ray	Covid-19	92.18
[39]	2020	X-ray	Covid-19	91.24
[40]	2020	CT	Covid-19	93.1
[41]	2020	CT	Covid-19	94.03
[42]	2016	Histology	Colon Cancer	91
[43]	2017	Histology	Colon Cancer	95.8
[44]	2020	Histology	Colon Cancer	90.4
[45]	2018	Histology	Colon Cancer	80.61
[46]	2021	Histology	Colon Cancer	96.16
[47]	2015	Endoscopic	Digestive Cancer	95
[48]	2015	Endoscopic	Digestive Cancer	97.25
[49]	2017	lesion images	Skin cancer	72.1
[50]	2020	Endoscopic	Gastric Cancer	88.9
[50]	2020	Endoscopic	Gastric Cancer	81.9
[51]	2018	Endoscopic	Gastric Cancer	96
[52]	2016	fMRI	Alzheimer's	96.85
[53]	2016	CT	Alzheimer's	88.8
[54]	2021	MRI	Alzheimer's	79
[55]	2021	MRI	Alzheimer's	99
[56]	2021	MRI	Alzheimer's	94
[57]	2022	MRI	Alzheimer's	91
[58]	2017	MRI	Alzheimer's	73
[59]	2016	CT	Breast Cancer	89
[60]	2019	X-ray	Breast Cancer	90.5
[61]	2018	Microscopic	Breast Cancer	98.33
[62]	2017	Spectrogram	Epilepsy	72.49
[63]	2019	Spectrogram	Epilepsy	99.5
[64]	2019	Spectrogram	Epilepsy	86.25
[65]	2020	Spectrogram	Epilepsy	88.3
[66]	2018	Spectrogram	Epilepsy	96.7
[67]	2021	Spectrogram	Epilepsy	100
[68]	2021	MRI	Brain Cancer	94.6
[69]	2022	MRI	Brain Cancer	88.18
[70]	2022	MRI	Brain Cancer	98.70
Quantum Convolutional Neural Networks				
[71]	2022	X-ray	COVID-19	98.1
[72]	2021	CT	COVID-19	96
[73]	2021	X-ray	COVID-19	99
[74]	2020	Cell	Breast cancer	98.9
[75]	2022	Ultrasound	Breast cancer	99
[76]	2022	X-ray	Breast cancer	84
[77]	2022	X-ray	Coronary Angiography	91.8
[78]	2022	X-ray	Pneumonia	74.6
[79]	2022	X-ray	Pneumonia	100
[80]	2022	OCT	Diabetic Retinopathy	99
[81]	2022	MRI	Tumor	83

## VI. REFERENCES

- [1] H. A. Jasim, S. R. Ahmed, A. A. Ibrahim, and A. D. Duru, "Classify Bird Species Audio by Augment Convolutional Neural Network," in *2022 International Congress on Human-Computer Interaction, Optimization and Robotic Applications (HORA)*, 2022, pp. 1-6: IEEE.
- [2] Z. A. Abbood, B. T. Yasen, M. R. Ahmed, and A. D. Duru, "Speaker identification model based on deep neural networks," *Iraqi Journal For Computer Science and Mathematics*, vol. 3, no. 1, pp. 108-114, 2022.
- [3] M. I. Razzak, S. Naz, and A. Zaib, "Deep learning for medical image processing: Overview, challenges and the future," *Classification in BioApps*, pp. 323-350, 2018.
- [4] V. Sharma, M. Gupta, A. Kumar, and D. Mishra, "Video Processing Using Deep Learning Techniques: A Systematic Literature Review," *IEEE Access*, 2021.
- [5] A. Voulodimos, N. Doulamis, A. Doulamis, and E. Protopapadakis, "Deep learning for computer vision: A brief review," *Computational intelligence and neuroscience*, vol. 2018, 2018.
- [6] A. Esteva *et al.*, "Deep learning-enabled medical computer vision," *NPJ digital medicine*, vol. 4, no. 1, pp. 1-9, 2021.
- [7] D. W. Otter, J. R. Medina, and J. K. Kalita, "A survey of the usages of deep learning for natural language processing," *IEEE transactions on neural networks and learning systems*, vol. 32, no. 2, pp. 604-624, 2020.
- [8] A. Hamidinekoo, E. Denton, A. Rampun, K. Honnor, and R. Zwiggelaar, "Deep learning in mammography and breast histology, an overview and future trends," *Medical image analysis*, vol. 47, pp. 45-67, 2018.
- [9] S. Al-jumaili, D. G. Duru, B. Ucan, O. N. Uçan, and A. D. Duru, "Classification of Covid-19 Effected CT Images using a Hybrid Approach Based on Deep Transfer Learning and Machine Learning," 2022.
- [10] Y. Rivenson, Z. Göröcs, H. Günaydin, Y. Zhang, H. Wang, and A. Ozcan, "Deep learning microscopy," *Optica*, vol. 4, no. 11, pp. 1437-1443, 2017.
- [11] F. Xing, Y. Xie, H. Su, F. Liu, and L. Yang, "Deep learning in microscopy image analysis: A survey," *IEEE transactions on neural networks and learning systems*, vol. 29, no. 10, pp. 4550-4568, 2017.
- [12] S. Al-Jumaili, A. Al-Azzawi, A. D. Duru, and A. A. Ibrahim, "Covid-19 X-ray image classification using SVM based on Local Binary Pattern," in *2021 5th International Symposium on Multidisciplinary Studies and Innovative Technologies (ISMSIT)*, 2021, pp. 383-387: IEEE.
- [13] S. Al-Jumaili, A. D. Duru, and O. N. Uçan, "Covid-19 Ultrasound image classification using SVM based on kernels deduced from Convolutional neural network," in *2021 5th International Symposium on Multidisciplinary Studies and Innovative Technologies (ISMSIT)*, 2021, pp. 429-433: IEEE.
- [14] F. E. Al-Khuzai, O. Bayat, and A. D. Duru, "Diagnosis of Alzheimer disease using 2D MRI slices by convolutional neural network," *Applied Bionics and Biomechanics*, vol. 2021, 2021.
- [15] G. Battineni, N. Chintalapudi, F. Amenta, and E. Traini, "A comprehensive machine-learning model applied to magnetic resonance imaging (MRI) to predict Alzheimer's disease (AD) in older subjects," *Journal of Clinical Medicine*, vol. 9, no. 7, p. 2146, 2020.
- [16] K. O'Shea and R. Nash, "An introduction to convolutional neural networks," *arXiv preprint arXiv:1511.08458*, 2015.
- [17] I. Cong, S. Choi, and M. D. Lukin, "Quantum convolutional neural networks," *Nature Physics*, vol. 15, no. 12, pp. 1273-1278, 2019.
- [18] Y. Jia *et al.*, "Caffe: Convolutional architecture for fast feature embedding," in *Proceedings of the 22nd ACM international conference on Multimedia*, 2014, pp. 675-678.
- [19] M. Abadi *et al.*, "Tensorflow: Large-scale machine learning on heterogeneous distributed systems," *arXiv preprint arXiv:1603.04467*, 2016.
- [20] R. Al-Rfou *et al.*, "Theano: A Python framework for fast computation of mathematical expressions," *arXiv e-prints*, p. arXiv:1605.02688, 2016.
- [21] V. Bergholm *et al.*, "Pennylane: Automatic differentiation of hybrid quantum-classical computations," *arXiv preprint arXiv:1811.04968*, 2018.
- [22] T. Alexander *et al.*, "Qiskit pulse: Programming quantum computers through the cloud with pulses," *Quantum Science and Technology*, vol. 5, no. 4, p. 044006, 2020.
- [23] M. Broughton *et al.*, "Tensorflow quantum: A software framework for quantum machine learning," *arXiv preprint arXiv:2003.02989*, 2020.
- [24] A. Gold *et al.*, "Entanglement across separate silicon dies in a modular superconducting qubit device," *npj Quantum Information*, vol. 7, no. 1, pp. 1-10, 2021.
- [25] A. Heidenreich, F. Desgrandschamps, and F. Terrier, "Modern approach of diagnosis and management of acute flank pain: review of all imaging modalities," *European urology*, vol. 41, no. 4, pp. 351-362, 2002.
- [26] M. M. Rahman, B. C. Desai, and P. Bhattacharya, "Medical image retrieval with probabilistic multi-class support vector machine classifiers and adaptive similarity fusion," *Computerized Medical Imaging and Graphics*, vol. 32, no. 2, pp. 95-108, 2008.
- [27] S. Oh, J. Choi, and J. Kim, "A tutorial on quantum convolutional neural networks (QCNN)," in *2020 International Conference on Information and Communication Technology Convergence (ICTC)*, 2020, pp. 236-239: IEEE.
- [28] C. H. Bennett, E. Bernstein, G. Brassard, and U. Vazirani, "Strengths and weaknesses of quantum computing," *SIAM journal on Computing*, vol. 26, no. 5, pp. 1510-1523, 1997.
- [29] T. Hur, L. Kim, and D. K. Park, "Quantum convolutional neural network for classical data classification," *Quantum Machine Intelligence*, vol. 4, no. 1, pp. 1-18, 2022.
- [30] A. Matic, M. Monnet, J. M. Lorenz, B. Schachtner, and T. Messerer, "Quantum-classical convolutional neural networks in radiological image classification," *arXiv preprint arXiv:2204.12390*, 2022.
- [31] G. Acampora and R. Schiattarella, "Deep neural networks for quantum circuit mapping," *Neural Computing and Applications*, vol. 33, no. 20, pp. 13723-13743, 2021.
- [32] M. Gao *et al.*, "Holistic classification of CT attenuation patterns for interstitial lung diseases via deep convolutional neural networks," *Computer Methods in Biomechanics and Biomedical Engineering: Imaging & Visualization*, vol. 6, no. 1, pp. 1-6, 2018.
- [33] W. Shen *et al.*, "Multi-crop convolutional neural networks for lung nodule malignancy suspiciousness classification," *Pattern Recognition*, vol. 61, pp. 663-673, 2017.
- [34] X. Gao, W. Li, M. Loomes, and L. Wang, "A fused deep learning architecture for viewpoint classification of echocardiography," *Information Fusion*, vol. 36, pp. 103-113, 2017.
- [35] M. Farooq and A. Hafeez, "Covid-resnet: A deep learning framework for screening of covid19 from radiographs," *arXiv preprint arXiv:2003.14395*, 2020.
- [36] D. Ezzat and H. A. Ella, "GSA-DenseNet121-COVID-19: a hybrid deep learning architecture for the diagnosis of COVID-19 disease based on gravitational search optimization algorithm," *arXiv preprint arXiv:2004.05084*, 2020.
- [37] T. Li, Z. Han, B. Wei, Y. Zheng, Y. Hong, and J. Cong, "Robust screening of covid-19 from chest x-ray via discriminative cost-sensitive learning," *arXiv preprint arXiv:2004.12592*, 2020.
- [38] K. El Asnaoui and Y. Chawki, "Using X-ray images and deep learning for automated detection of coronavirus disease," *Journal of Biomolecular Structure and Dynamics*, pp. 1-12, 2020.
- [39] H. Enders, F. Cortese, C. Maurer, J. Baltich, A. B. Protzner, and B. M. Nigg, "Changes in cortical activity measured with EEG during a high-intensity cycling exercise," *Journal of neurophysiology*, vol. 115, no. 1, pp. 379-388, 2016.
- [40] Y. Pathak, P. K. Shukla, A. Tiwari, S. Stalin, and S. Singh, "Deep transfer learning based classification model for COVID-19 disease," *Irbm*, 2020.
- [41] U. Özkaya, Ş. Öztürk, S. Budak, F. Melgani, and K. Polat, "Classification of COVID-19 in Chest CT Images using Convolutional Support Vector Machines," *arXiv preprint arXiv:2011.05746*, 2020.
- [42] K. Sirinukunwattana, S. E. A. Raza, Y.-W. Tsang, D. R. Snead, I. A. Cree, and N. M. Rajpoot, "Locality sensitive deep learning for detection and classification of nuclei in routine colon cancer histology images," *IEEE transactions on medical imaging*, vol. 35, no. 5, pp. 1196-1206, 2016.
- [43] B. Korbar *et al.*, "Deep learning for classification of colorectal polyps on whole-slide images," *Journal of pathology informatics*, vol. 8, no. 1, p. 30, 2017.

- [44] Z. Song *et al.*, "Automatic deep learning-based colorectal adenoma detection system and its similarities with pathologists," *BMJ open*, vol. 10, no. 9, p. e036423, 2020.
- [45] S. S. Basha, S. Ghosh, K. K. Babu, S. R. Dubey, V. Pulabaigari, and S. Mukherjee, "Rcnet: An efficient convolutional neural network for histological routine colon cancer nuclei classification," in *2018 15th International Conference on Control, Automation, Robotics and Vision (ICARCV)*, 2018, pp. 1222-1227: IEEE.
- [46] E. Paladini, E. Vantaggiato, F. Bougourzi, C. Distanto, A. Hadid, and A. Taleb-Ahmed, "Two ensemble-CNN approaches for colorectal cancer tissue type classification," *Journal of Imaging*, vol. 7, no. 3, p. 51, 2021.
- [47] Y. Zou, L. Li, Y. Wang, J. Yu, Y. Li, and W. Deng, "Classifying digestive organs in wireless capsule endoscopy images based on deep convolutional neural network," in *2015 IEEE International Conference on Digital Signal Processing (DSP)*, 2015, pp. 1274-1278: IEEE.
- [48] J.-s. Yu, J. Chen, Z. Xiang, and Y.-X. Zou, "A hybrid convolutional neural networks with extreme learning machine for WCE image classification," in *2015 IEEE International Conference on Robotics and Biomimetics (ROBIO)*, 2015, pp. 1822-1827: IEEE.
- [49] A. Esteva *et al.*, "Dermatologist-level classification of skin cancer with deep neural networks," *nature*, vol. 542, no. 7639, pp. 115-118, 2017.
- [50] P. An *et al.*, "A deep learning method for delineating early gastric cancer resection margin under chromoendoscopy and white light endoscopy," *Gastric Cancer*, vol. 23, no. 5, pp. 884-892, 2020.
- [51] X. Liu, C. Wang, J. Bai, and G. Liao, "Fine-tuning pre-trained convolutional neural networks for gastric precancerous disease classification on magnification narrow-band imaging images," *Neurocomputing*, vol. 392, pp. 253-267, 2020.
- [52] S. Sarraf and G. Tofghi, "Classification of alzheimer's disease using fmri data and deep learning convolutional neural networks," *arXiv preprint arXiv:1603.08631*, 2016.
- [53] X. W. Gao and R. Hui, "A deep learning based approach to classification of CT brain images," in *2016 SAI Computing Conference (SAI)*, 2016, pp. 28-31: IEEE.
- [54] R. Suganthe, M. Geetha, G. Sreekanth, K. Gowtham, S. Deepakkumar, and R. Elango, "Multiclass Classification of Alzheimer's Disease Using Hybrid Deep Convolutional Neural Network," *NVEO-NATURAL VOLATILES & ESSENTIAL OILS Journal| NVEO*, pp. 145-153, 2021.
- [55] S. Liang and Y. Gu, "Computer-Aided Diagnosis of Alzheimer's Disease through Weak Supervision Deep Learning Framework with Attention Mechanism," *Sensors*, vol. 21, no. 1, p. 220, 2021.
- [56] B. A. Mohammed *et al.*, "Multi-Method Analysis of Medical Records and MRI Images for Early Diagnosis of Dementia and Alzheimer's Disease Based on Deep Learning and Hybrid Methods," *Electronics*, vol. 10, no. 22, p. 2860, 2021.
- [57] B. Nicholas, A. Jayakumar, B. Titus, and T. Remya Nair, "Comparative Study of Multiple Feature Descriptors for Detecting the Presence of Alzheimer's Disease," in *Ubiquitous Intelligent Systems*: Springer, 2022, pp. 331-339.
- [58] J. Islam and Y. Zhang, "A novel deep learning based multi-class classification method for Alzheimer's disease detection using brain MRI data," in *International conference on brain informatics*, 2017, pp. 213-222: Springer.
- [59] D. Lévy and A. Jain, "Breast mass classification from mammograms using deep convolutional neural networks," *arXiv preprint arXiv:1612.00542*, 2016.
- [60] F. F. Ting, Y. J. Tan, and K. S. Sim, "Convolutional neural network improvement for breast cancer classification," *Expert Systems with Applications*, vol. 120, pp. 103-115, 2019.
- [61] D. Bardou, K. Zhang, and S. M. Ahmad, "Classification of breast cancer based on histology images using convolutional neural networks," *Ieee Access*, vol. 6, pp. 24680-24693, 2018.
- [62] W. Mao, H. Fathurrahman, Y. Lee, and T. Chang, "EEG dataset classification using CNN method," in *Journal of physics: conference series*, 2020, vol. 1456, no. 1, p. 012017: IOP Publishing.
- [63] Ö. Türk and M. S. Özerdem, "Epilepsy detection by using scalogram based convolutional neural network from EEG signals," *Brain sciences*, vol. 9, no. 5, p. 115, 2019.
- [64] W. Hu, J. Cao, X. Lai, and J. Liu, "Mean amplitude spectrum based epileptic state classification for seizure prediction using convolutional neural networks," *Journal of Ambient Intelligence and Humanized Computing*, pp. 1-11, 2019.
- [65] S. Raghu, N. Sriraam, Y. Temel, S. V. Rao, and P. L. Kubben, "EEG based multi-class seizure type classification using convolutional neural network and transfer learning," *Neural Networks*, vol. 124, pp. 202-212, 2020.
- [66] M. Zhou *et al.*, "Epileptic seizure detection based on EEG signals and CNN," *Frontiers in neuroinformatics*, vol. 12, p. 95, 2018.
- [67] A. Yildiz, H. Zan, and S. Said, "Classification and analysis of epileptic EEG recordings using convolutional neural network and class activation mapping," *Biomedical Signal Processing and Control*, vol. 68, p. 102720, 2021.
- [68] M. S. Fuad, C. Anam, K. Adi, and G. Dougherty, "Comparison of two convolutional neural network models for automated classification of brain cancer types," in *AIP Conference Proceedings*, 2021, vol. 2346, no. 1, p. 040008: AIP Publishing LLC.
- [69] D. Filatov and G. N. A. H. Yar, "Brain Tumor Diagnosis and Classification via Pre-Trained Convolutional Neural Networks," *medRxiv*, 2022.
- [70] M. Ait Amou, K. Xia, S. Kamhi, and M. Mouhafid, "A Novel MRI Diagnosis Method for Brain Tumor Classification Based on CNN and Bayesian Optimization," in *Healthcare*, 2022, vol. 10, no. 3, p. 494: MDPI.
- [71] E. H. Houssein, Z. Abohashima, M. Elhoseny, and W. M. Mohamed, "Hybrid quantum-classical convolutional neural network model for COVID-19 prediction using chest X-ray images," *Journal of Computational Design and Engineering*, vol. 9, no. 2, pp. 343-363, 2022.
- [72] J. Amin, M. Sharif, N. Gul, S. Kadry, and C. Chakraborty, "Quantum machine learning architecture for COVID-19 classification based on synthetic data generation using conditional adversarial neural network," *Cognitive Computation*, pp. 1-12, 2021.
- [73] M. J. Umer, J. Amin, M. Sharif, M. A. Anjum, F. Azam, and J. H. Shah, "An integrated framework for COVID - 19 classification based on classical and quantum transfer learning from a chest radiograph," *Concurrency and Computation: Practice and Experience*, p. e6434, 2021.
- [74] A. Bisarya *et al.*, "Breast cancer detection using quantum convolutional neural networks: A demonstration on a quantum computer," *medRxiv*, 2020.
- [75] J. Amin, M. Sharif, S. L. Fernandes, S. H. Wang, T. Saba, and A. R. Khan, "Breast microscopic cancer segmentation and classification using unique 4 - qubit - quantum model," *Microscopy Research and Technique*, vol. 85, no. 5, pp. 1926-1936, 2022.
- [76] V. Azevedo, C. Silva, and I. Dutra, "Quantum transfer learning for breast cancer detection," *Quantum Machine Intelligence*, vol. 4, no. 1, pp. 1-14, 2022.
- [77] E. Ovalle-Magallanes, J. G. Avina-Cervantes, I. Cruz-Aceves, and J. Ruiz-Pinales, "Hybrid classical-quantum Convolutional Neural Network for stenosis detection in X-ray coronary angiography," *Expert Systems with Applications*, vol. 189, p. 116112, 2022.
- [78] V. Kulkarni, S. Pawale, and A. Kharat, "A Classical-Quantum Convolutional Neural Network for Detecting Pneumonia from Chest Radiographs," *arXiv preprint arXiv:2202.10452*, 2022.
- [79] M. N. Tayba, A. Al, and J. Orduz, "Using Quantum Circuits with Convolutional Neural Network for Pneumonia Detection."
- [80] S. Sridevi, T. Kanimozhi, S. Bhattacharjee, D. Shahwar, and K. S. S. Reddy, "Quantum Transfer Learning for Diagnosis of Diabetic Retinopathy," in *2022 International Conference on Innovative Trends in Information Technology (ICITIT)*, 2022, pp. 1-5: IEEE.
- [81] T. Kanimozhi, S. Sridevi, T. S. Manikumar, T. Dheeraj, and A. Sumanth, "Brain Tumor Recognition based on Classical to Quantum Transfer Learning," in *2022 International Conference on Innovative Trends in Information Technology (ICITIT)*, 2022, pp. 1-5: IEEE.