

## An electronic portable device design to spectroscopically assess fruit quality

Ali SARIKAŞ<sup>1,2,\*</sup>, Merve DOĞRUYOL BAŞAR<sup>2</sup>

<sup>1</sup>Department of Electronics and Automation, Vocational School of Technical Sciences, Marmara University, İstanbul, Turkey

<sup>2</sup>Department of Biomedical Engineering, Faculty of Engineering, İstanbul University, İstanbul, Turkey

Received: 03.10.2016

Accepted/Published Online: 25.02.2017

Final Version: 05.10.2017

**Abstract:** As a rapid and nondestructive sensing technique, reflection spectroscopy is useful in monitoring and managing horticultural production; in other words, the ripening of fruits and vegetables can be evaluated using reflection spectroscopy. Based on laboratory data obtained from an ultraviolet/visible/near-infrared (UV/Vis/NIR) spectrophotometer with a diffuse reflectance accessory, we developed a prototype handheld device. The device operates at a range of 400 nm to 1100 nm (blue, green, red, and NIR). LEDs, photodiodes, a microcontroller, digital-to-analog converters, a graphical LCD display, and a keypad were used for instrumentation. With our user-friendly software interface, measurements can be performed and controlled in real time, and measured data can be transferred to a computer using Bluetooth technology. This method of processing and evaluating data is easily managed.

**Key words:** Nondestructive testing, visible/near-infrared diffuse reflectance spectroscopy, fruit quality assessment, handheld device, Bluetooth

### 1. Introduction

Ultraviolet/visible/near-infrared (UV/Vis/NIR) spectroscopy has been widely used since the 1960s to nondestructively assess the quality of daily-consumed fresh produce like fruits and vegetables [1–3]. A survey in the literature shows that Vis spectroscopy is useful for external quality assessment, whereas NIR spectroscopy provides information on internal properties such as flesh maturity/ripening and starch and water content. Lamertyn et al. analyzed the sugar content, acidity, firmness, and water content of apples [4], whereas Carlamagno et al. analyzed the sugar content of peaches [5]. Sirisomboon et al. analyzed the sugar content of pears [6], while Galvao et al. analyzed the water, sugar, sucrose, and reduced sugar content of sugar beet [7]. Liu et al. investigated the potential of Vis/NIR spectrometry technique to nondestructively measure soluble solids content (SSC) and the firmness of intact pear fruit [8], whereas Minaei et al. investigated the feasibility of reflectance Vis/NIR spectroscopy for taste characterization of Valencia oranges based on taste attributes including SSC [9]. Peirs et al. used Vis/NIR spectroscopy to nondestructively determine the internal quality and optimal harvest dates of apples [10], while Cayuela analyzed the SSC of oranges [11]. Moghimi et al. analyzed the internal quality of kiwifruit [12], and Lin and Ying reviewed significant progresses achieved in fruit quality assessment via NIR spectroscopy for a period of 11 years [13]. Cortes et al. [14] developed a new internal quality index based on the combination of SSC, firmness, and color of mango fruit. They used diffuse reflectance Vis/NIR

\*Correspondence: ali.sarikas@marmara.edu.tr

spectroscopy that operated at both 600–1100 nm and 900–1750 nm wavelength ranges. For visible ranges, a spectroradiometer was also used. The results obtained from their study showed that external visible and near-infrared reflection spectroscopy can be used as a nondestructive method to evaluate the internal quality of mangoes. In another study [15], Gao et al. developed a light emitting diode (LED)-induced fluorescence spectroscopy technique to determine the freshness and quality of apples. The experimental setup was designed as fully automatic and consisted of a computer, DAQ, step motor, spectrometer, fiber-optic bundle, LEDs (at 375 nm and 400 nm), and long-pass filters. The measurement signals were transmitted to the computer by the DAQ and processed with MATLAB software (MathWorks Inc., Natick, MA, USA). A LabVIEW (National Instruments, Austin, TX, USA) program was utilized to control both the DAQ and spectrometer to achieve automatic measurement.

Some reports in the literature in the last decade have showed that various portable or handheld devices/spectrometers can be used for nondestructive determination of fruit quality. Although they are referred to as portable devices, they need a signal-processing device such as a computer. Generally, in these studies destructive measurements were utilized first and then NIR data modeling with parameters related to internal and external qualities was initiated, so a fully automatic portable device design has not been found in the literature. When studies of the use of partially portable devices are examined, Camps and Christen [16] comprehensively reported that NIR spectroscopy technology could be applicable for determining apricot quality and that such portable devices could help to obtain maturity information of fruit in orchards. The authors used a single-beam Vis/NIR spectrometer in reflectance mode (Ocean Optics S-2000, USA) with a standard diffraction grating (650–1200 nm, near-infrared), a 10-W tungsten halogen lamp as the light source, and a 7200- $\mu\text{m}$  optical fiber to direct the reflected light to the spectrometer. They first measured the firmness of apricots using a Durofel device fitted with a 0.10-cm<sup>2</sup> probe (Durofel, Agro Technologie, France). After firmness measurements were carried out, each fruit was mixed using a juice centrifuge and the obtained juice was filtered using filter paper (S&S Faltenfilter, LS 14.5, Schleicher & Schüll, Germany). The SSC of this filtered fruit juice was determined using a refractometer (Model PR-1, Atago Ltd., Tokyo, Japan). Final parameters and total acidity were measured using a titrimeter (Titrino 719S, Metrohm, Switzerland). All obtained data from destructive measurements were used to extract a linear model with NIR spectral data. They used the MATLAB 6.0 environment (MathWorks Inc.) to carry out all the statistical procedures. In another study [17], researchers used a portable NIR spectrophotometer to assess the internal and external quality of mandarins on trees at harvest time. They collected NIR spectral data using a handheld microelectromechanical system (MEMS) instrument in reflectance mode ( $\log 1/R$ ) (Phazir 2400, Polychromix Inc., Wilmington, MA, USA). This instrument operates between 1600 nm and 2400 nm with an 8-nm sampling interval. In short, four spectral measurements were made taking into account the orientation (north, south, east, and west) for each fruit without plucking. The four spectra were averaged to provide a mean spectrum for each fruit. A study conducted by Blakey [18] evaluated avocado fruit maturity with a portable NIR spectrometer (Phazir 1018) that operates in a wavelength region of 940–1798 nm with resolution of 8–9 nm with 100 data points per spectra. The author also reported that the measurement of a single fruit took 30 s and could be conducted pre- or postharvest. Similar to the study in [16], in which in situ quality assessment of intact oil palm fresh fruit bunches was carried out, an experimental setup consisting of a portable spectrometer, a fiber-optic cable, and a tungsten halogen lamp was used in Makky and Soni's study [19]. In another new study [20], researchers presented a systematized method for predicting water content, fat content, and free acidity in olive fruits by online NIR spectroscopy combined with chemometric techniques such as principal component analysis, linear discriminant analysis, and partial least squares regression.

In light of all of the previous studies, we first analyzed 12 different fruits (3 kinds of apples (Granny Smith, Starking, and Golden) and plums, pears, peaches, apricots, kiwis, oranges, pomegranates, strawberries, and quinces from organic gardens) using diffuse reflectance spectroscopy at a range of 280–2500 nm. Considering the operational principles of conventional reflectance spectroscopy systems, we decided to design and implement a simple, yet improved, portable and robust handheld device for fruit-quality assessment in the field. We also wanted to particularly determine color/pigmentation, water content, and ripening.

In our design, we used LEDs as light sources and, to minimize the so-called banana-shape effect, photodiodes were placed in an elliptical manner around the LEDs to detect reflected light from the surface of inspected fruit samples [21]. All electronic components were surface-mounted devices. Thus, the circuit board could be miniaturized and light-weight, and the device was made small enough to be handheld. Another advantage of our device is rapid analysis of measurements using reference data already stored on the device's micro SD card.

## 2. Background

Conventional laboratory methods for determination of chlorophyll, water content, and cellular structure of fresh produce are very time-consuming and, at times, destructive to the sample. A sample must be typically cut/sliced/diced or ground up in a solvent and then assayed using a spectrophotometer. Therefore, a sample can be tested only once at a particular time-point in the growing cycle. Our prime design objective was to design a device that would make possible repetitive, nondestructive, and rapid measurements with automatic averaging calculations of relative chlorophyll, water content, and starchiness.

The interaction of light with organic matter is predominantly determined by the absorption and scattering of organic molecules. Pigments (porphyrin/chlorophyll) are largely absorbed in the UV and visible range, whereas water absorption is dominant in the NIR and IR. Scattering is immense in the visible range, yet it logarithmically decreases with increasing wavelengths. The effects of scattering are negligible in the IR due to high water absorption. Subsequently, the transition range from the visible range to shortwave IR, where scattering dominates over absorption, provides invaluable information on cellular/molecular structure (starchiness), as shown in Figure 1.

## 3. Materials and methods

### 3.1. Fruit samples

During our predesign laboratory work, we made measurements using various fruits, including Granny Smith, Starking, and Golden apples and plums, pears, peaches, apricots, kiwis, oranges, pomegranates, strawberries, and quinces. In total, 60 different fruit specimens of different ripeness were assessed. Samples were prepared as follows: fruits with uniform pericarp were washed and cleaned, and we directly cut parallel slices into the fruit flesh. The outermost slices were used for measurements, unless indicated otherwise.

### 3.2. UV/Vis/NIR measurements in the laboratory

Our measurements were carried out in research laboratories in İstanbul. We used a Lambda 900 spectrophotometer (PerkinElmer, Waltham, MA, USA) with a reflectance accessory (Figure 2). The Lambda 900 is a bulky and expensive device due to its high capacity to take measurements of the chemometric properties of a numerous variety of materials. Measurement of each fruit takes about 10 min. This can be seen as a disadvantage. The Lambda 900 spectrophotometer is an optical system that performs reflection measurements made up of dual

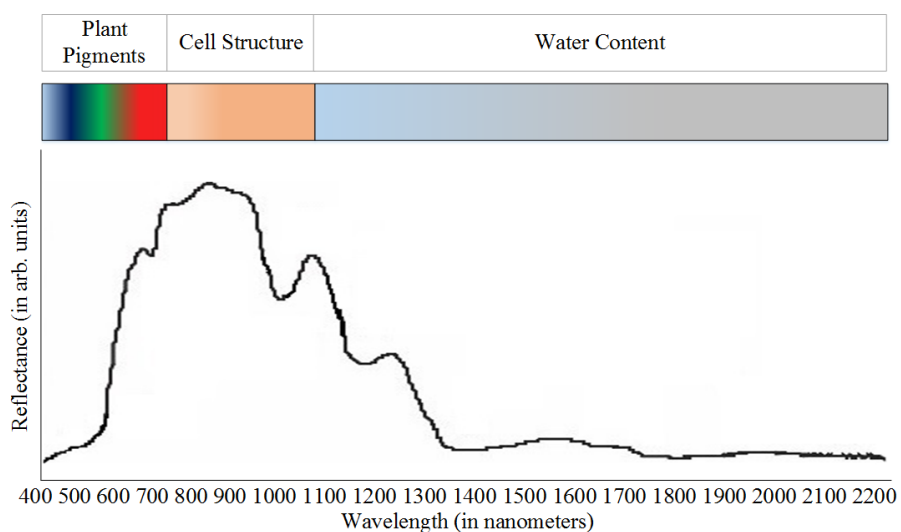

**Figure 1.** Factors controlling diffuse scattering in UV/Vis/NIR.

monochromators. Holographic gratings are used for monochromators in the UV/Vis/NIR areas. The optical system has two light sources. These sources are deuterium and halogen lamps, which cover the wavelengths of the UV/Vis/NIR spectrum. In addition to these accessories, the Lambda 900 has mirrors, pinholes, filters, and a photomultiplier tube. Measurements were performed at 5-nm intervals in the range of 280–2500 nm. The pericarp side was attached to the sample port of the reflectance accessory for measurements.

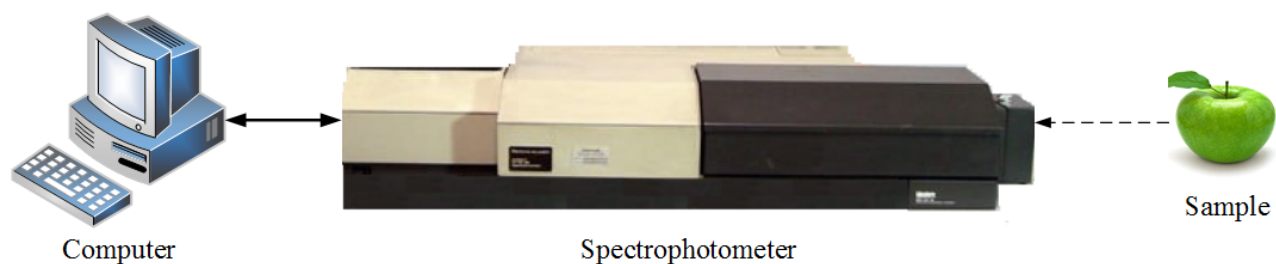

**Figure 2.** Experimental setup for laboratory practices.

The fruit is touched to the device as shown in Figure 3. The light is sent from the device to the tissue surface, and the light scattered back from the fruit's texture is detected. Measurements are taken using a signal collected by the integrating sphere found inside the device. The diffuse reflected light is also digitized and recorded by the computer interface software of the device via the RS232 serial interface.

### 3.3. Hardware design of the hand-held device

Considering the general operating principles of professional devices and the specific wavelength ranges in which fruit pericarp/flesh (pigments and water) absorbs and/or scatters light, we designed our device to have the following characteristics: portable, stand-alone, handheld, ultralow power, and low cost. LEDs were used as light sources because they are small, have fast response times in the nanosecond range, have low electric power consumption in switching regimes, and possess relatively long lifetimes of up to 50,000–80,000 h. Professional devices such as the Lambda 900 have deuterium and/or halogen lamps to cover the spectrum. Using such



**Figure 3.** Sample and device interaction during measurements.

accessories like gratings and filters and mirrors, certain wavelengths (of at least 5-nm intervals) can be obtained. As the wavelength interval of the produced light decreases, the duration of the process is prolonged. Our prototype device using specific LED light sources is suitable for taking measurements. We observed and experimented on almost every kind of fruit in reflected or absorbed light at specific wavelengths (Table 1), and we used RGB, LED, and NIR-LED in the design. Our device's components are schematically shown in Figure 4.

**Table 1.** Reflection and absorption peaks (400–1100 nm range).

Fruit	Wavelength (nm)													
	435	475	490	510	565	635	660	680	725	755	875	920	975	1070
Kiwi			✓		✓	✓	✓		✓			✓	✓	✓
Pear			✓		✓	✓		✓		✓		✓	✓	✓
Plum			✓		✓	✓		✓		✓		✓	✓	✓
Peach	✓			✓			✓	✓	✓				✓	✓
Orange		✓			✓			✓	✓		✓	✓	✓	✓
Quince		✓			✓		✓			✓	✓		✓	✓
Apricot	✓			✓	✓		✓	✓					✓	✓
Strawberry	✓				✓		✓		✓		✓	✓	✓	✓
Pomegranate	✓	✓			✓	✓		✓		✓			✓	✓
Starking					✓		✓	✓	✓		✓	✓	✓	✓
Granny Smith		✓	✓	✓	✓	✓		✓			✓			✓
Golden			✓	✓			✓	✓	✓	✓		✓	✓	✓

We used two light sources covering the visible range (400–700 nm) and NIR (700–1100 nm). For the visible range, we used an RGB (red-green-blue) LED. Using the DAC, the RGB can be driven. For the NIR, we used a NIR-LED with an emission peak of 875 nm. Bulky, professional, and commercial devices have photomultiplier tubes that are very expensive accessories and used for light detectors, whereas our prototype device has PIN photodiodes, which provide the fastest response and have high quantum efficiency (0.9) compared to other devices. Eight silicon PIN photodiodes were arranged elliptically around the two LEDs to detect light reflected off the pericarp of the fruit, unless otherwise indicated. With such an elliptical arrangement, we assumed that our measurements were minimally sensitive to the “banana-shape effect”, as illustrated in Figure 5.

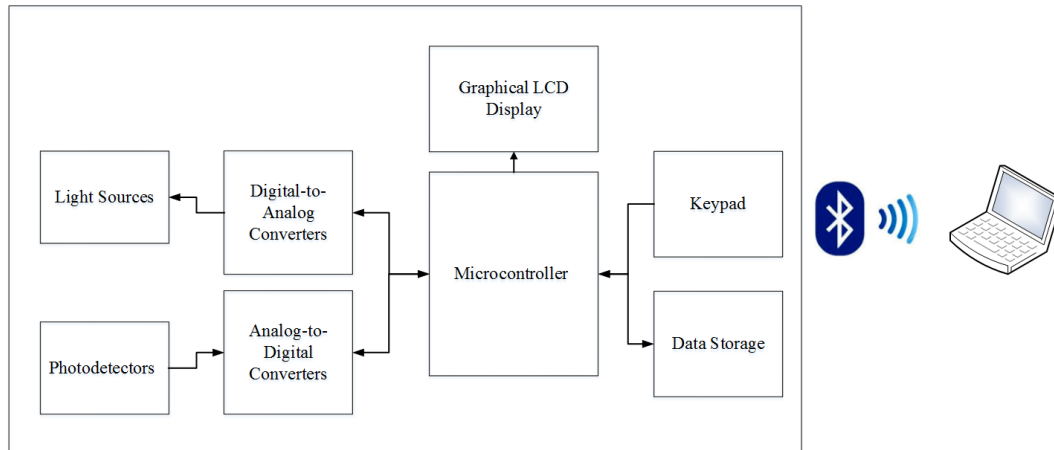

Figure 4. Hardware design of our device.

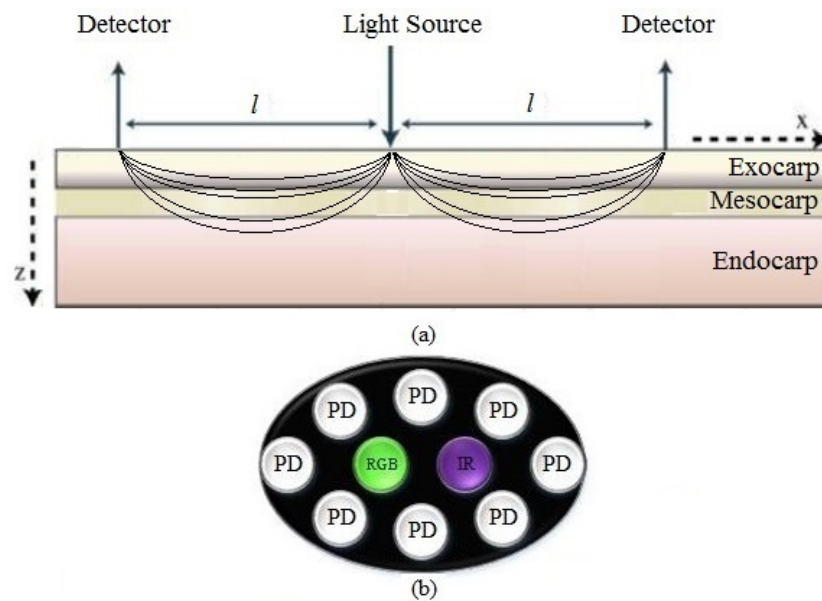

Figure 5. a) Banana-shape effect and b) arrangement of LEDs and photodiodes to minimize banana-shape effect (PD: photo detector; RGB: red-green-blue LED light source; IR: near-infrared LED light source).

Microcontrollers are integrated circuits that house all the structures such as input/output units (to provide communication with peripheral units), central processing unit (CPU), and random access memory that must be found in a stand-alone computer. The structures of microcontrollers and computers are quite similar. A PIC18F4550 microcontroller (Microchip Technology Inc., Austin, TX, USA) was used because of its superior features. Significant features of the microcontroller are listed below:

- Program memory: 32 Kbytes flash and 16,384 single-word instructions
- Data memory: 2048 bytes SRAM and 256 bytes EEPROM
- 35 I/O ports
- 10-bit, up to 13-channel analog-to-digital converter (A/D) module with programmable acquisition time

- Up to 2 capture/compare/PWM modules (capture is 16-bit, max. resolution 5.2 ns, compare is 16-bit, max. resolution 83.3 ns, and PWM output: PWM resolution is 1 to 10-bit)
- Enhanced capture/compare/PWM (ECCP) module
- Enhanced USART module
- Power-managed modes (run: CPU on, peripherals on, idle: CPU off, peripherals on, sleep: CPU off, peripherals off. Idle mode currents down to 5.8  $\mu\text{A}$  typical. Sleep mode currents down to 0.1  $\mu\text{A}$  typical)
- USB v2.0 compliant
- Priority levels for interrupts
- In-circuit debug via two pins
- 100,000 erase/write cycle enhanced flash program memory typical
- 1,000,000 erase/write cycle data EEPROM memory typical
- Flash/data EEPROM retention: more than 40 years

A  $128 \times 64$  bit graphic LCD and  $3 \times 4$  keypad were used for the user interface and user control of device functions. The functions of our device are three-fold:

- (i) Make measurements/take data,
- (ii) Save reference data,
- (iii) Transfer data to a main computer via Bluetooth.

We incorporated a micro SD card (currently 2 GB; if needed, its capacity can be increased) into the design to record measured data and store reference data. In this design, each complete measurement covers 16 B. Thus, there is enough space on the micro SD card for multiple measurements.

#### 4. Software design

The software algorithm is depicted in Figure 6. The software uses digital data from the analog-to-digital converter (ADC). In order to make a new measurement, reference data at each wavelength of interest must be residing in the device's memory, i.e. the micro SD card.

When our device is turned on, the first screen shows the 3 main functions mentioned above in Section 3.3. When the “make measurement” function is selected, previously recorded reference data are listed. At this point, users have to indicate which fruit they would like to test. After the measurement is completed, a new screen appears on the LCD, indicating (a) the wavelength at which a reflection peak is detected in the visible range (400–700 nm), (b) the normalized percent reflection at the wavelength indicated in (a), and (c) the peak value of the normalized percent reflection detected in the NIR range. If needed, our flexible software allows the user to “add” the newly recorded data to the already existing database for that specific fruit.

When the “record reference” function is selected, the fruit has to be brought closer to the LEDs and photodiodes. When ready, the user starts the reference measurement. To save or discard the recorded data, the

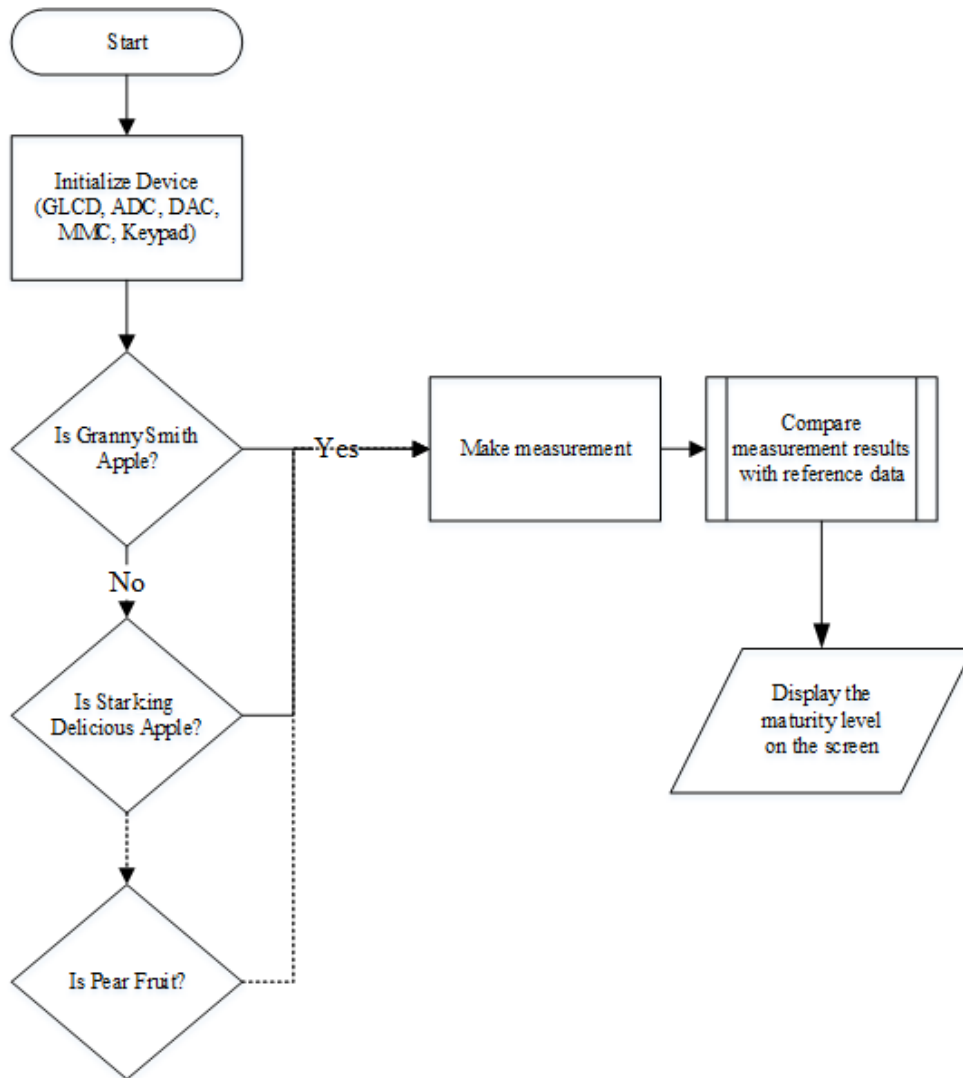

**Figure 6.** Main software algorithm for measurements.

user is prompted. If the user saves the data, the program prompts once again for a second measurement. This process can be repeated as many times as needed or required. Once a database for that specific fruit has been generated, the overall average of measured data at each wavelength is calculated and shown in graphic format on the LCD. This new graph shows the reference spectrum for that specific fruit. Using the alphanumeric keypad, the name of the fruit and other relevant information can be entered and saved.

When the “send to PC” function is selected, all reference and measured data for that specific fruit can be transferred to a PC via Bluetooth. The PC interface records all transferred data in .csv format for further statistical analysis.

#### 4.1. Calibration of the device

Calibration of single measurements is carried out according to the following formula (Eq. (1)):

$$m = \frac{S - D}{R - D}, \quad (1)$$

where:

$S$  is the detected reflection signal [V],

$D$  is the detected dark signal [V],

$R$  is the detected signal from a reference [V], and

$m$  is the normalized percent reflection.

Reference data for a specific fruit is obtained by using Eq. (2):

$$R_{\lambda} = \frac{[S_1 + S_2 + \dots + S_n]_{\lambda}}{n} , \quad (2)$$

where:

$R_{\lambda}$  is the arithmetic mean of reflection data for a specific fruit at specific wavelength  $\lambda$ ,

$S_1$  is the reflection off fruit sample 1 at specific wavelength  $\lambda$ ,

$S_2$  is the reflection off fruit sample 2 at specific wavelength  $\lambda$ ,

$S_n$  is the reflection off fruit sample n at specific wavelength  $\lambda$ , and

n is total number of samples for a specific fruit.

Important factors in calibration are the spectra of light sources and the spectral sensitivity of detectors. In the current design, we used 8 silicon PIN photodiodes sensitive in the range of 190–1240 nm. However, our device works in the range of 400–1100 nm. Fortunately, the full width-half maximum of the photodiodes overlaps with our operational range.

Monochromators are important and bulky components of spectrophotometers. However, for a handheld device, we had to come up with a new idea for wavelength selection. Operation of our device at a specific wavelength was made possible by DACs and dedicated software. The 10-bit data from a microcontroller were first sent to the DACs and then to the RGB LEDs to irradiate samples at specific wavelengths (480 nm, 520 nm, and 660 nm).

#### 4.2. The operation of the system

The fruit sample is placed so as to touch the sensory part (Figure 5b) of the device, as illustrated in Figure 7a. Using the keypad, the measurement process is started. The microcontroller interfaces with the DACs to drive light sources. The reason for the use of DACs is to provide flexible design for the measurement of different tissue types, such as different fruit samples. Backscattered and/or reflected light from the tissue is detected by silicon PIN photodiodes that provide the fastest response and cover the related spectral ranges. The detected signal is an analog signal and must be converted to a digital signal to be processed via microcontroller. This process is performed by the microcontroller's ADC channels. After evaluation of the measurement data, data can be recorded to the micro SD card and visualized on the screen (Figure 7b).

The processing time of the device differs according to its functions. The device has three main functions, as mentioned above. The “make measurement” function takes 10 s and the “record reference” function takes at least 10 s. This delay time varies depending on the number of references. The “send to PC” function takes about 20 s. Because the proposed device evaluates only peak wavelength values, it can perform very fast measurements compared to other devices. For example, each of the measurements took about 8 min because the Lambda 900 evaluated 445 wavelength values at 5-nm intervals at a range of 280–2500 nm. Each process with the proposed device takes an average of 10 s.



**Figure 7.** Use and operation of the proposed device: a) portable device and its use during measurement; b) graphical output of the measurement.

#### 4.3. Repeatability test of the measurement system

Repeatability ( $r$ ) of the proposed measurement system was calculated using one-way ANOVA. The  $r$  value is obtained by using Eq. (3):

$$r = \frac{MS_B - MS_W}{MS_B - MS_W + n_0 MS_W} \quad (3)$$

where  $MS_B$  is the mean square between groups,  $MS_W$  is the mean square within groups, and  $n_0$  is the weighted average number of observations per group (we have 4 observations per individual here).

#### 5. Results and discussion

Reflection and absorption peaks for the 12 different fruits from our laboratory measurements are shown in Table 1. In our first measurements, we observed distinct peaks overlapping with the peaks in our laboratory measurements using our device. We also observed that some peaks could be detected in all fruits, whereas other peaks were variety-specific. Variety-specific peaks are associated with particular pigments in fruit pericarp.

Dimensions of pigment molecules in pericarp are in general much smaller than the cellular structure of any fruit.

Therefore, scattering is predominantly determined by cellular structure and, along with water content, is an indicator of cellular ripening, as seen in Figure 8. In this figure, we can observe that normalized diffuse reflection off Granny Smith apples decreased by almost 35% within a period of a month and a half during ripening (10 June to 30 July 2013). By the end of July, the apples were so ripe that the absorption peak at 655 nm was at the highest level (the valley at 655 nm was at the lowest level). As a result, we can note that absorption varied inversely proportional to reflection.

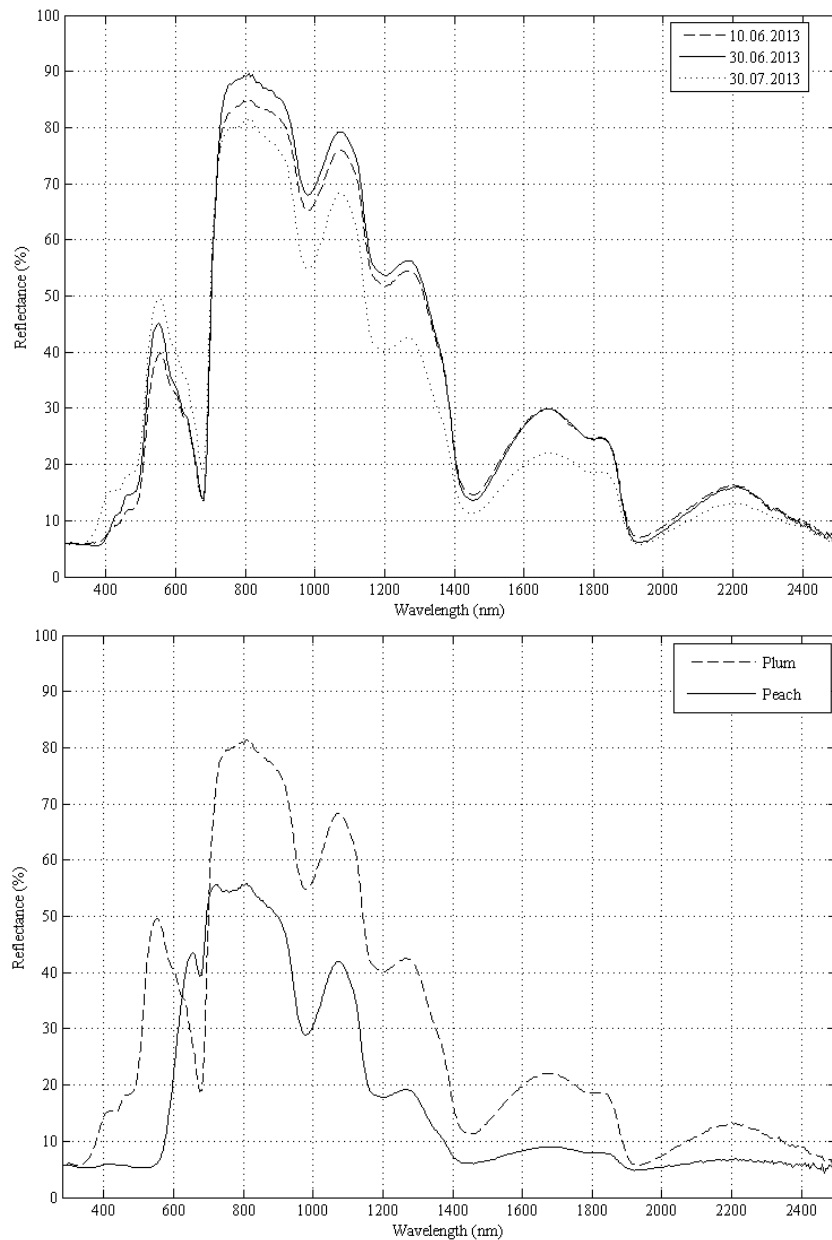

**Figure 8.** a) Measurements at different times on the same fruit (peaks and valleys at specific wavelengths but reflectance varied) and b) different variety of two fruits' reflectance spectra.

We also compared the performance and facilities of our custom-designed device and two commercially available devices on the market, as seen in Table 2. For the repeatability test, the measurement results of 10 different fruits of the same species (pear fruit), each with 4 observations, were used. The repeatability score was calculated as 0.487. It should be remembered that  $r$  ranges from 0 to 1, so an  $r$  value of 0.487 is quite consistent. In conclusion, this result means that about 49% of the variation is due to differences among individuals. The P-value is significantly smaller than 0.05 ( $P = 0.0005$ ), which is another important parameter proving this.

**Table 2.** Comparison of the performance of our device with two commercially available devices on the market.

Specifications/device	CCM-200 <sup>1</sup>	CM-2600d <sup>2</sup>	Our device
Measurement	Nondestructive	Nondestructive	Nondestructive
Weight	Approx. 165 g (including battery)	Approx. 670 g (excluding batteries)	Approx. 300 g (including battery)
Storage capacity	8 MB	N/A	2 GB
PC connectivity	USB and RS232	USB and RS232	Bluetooth (wireless comm.)
PC requirement	Stand alone operation (no PC required)	N/A	Stand alone operation (no PC required)
Power source	9 V alkaline battery	AA size 3 V alkaline batteries ( $\times 4$ ) and AC	3.7 V lithium polymer battery ( $\times 2$ ) (rechargeable)
Operating temperature	0°–50° C	0°–45° C	0°–75° C
Measured parameters	653 nm (chlorophyll) 931 nm (near infrared)	360–740 nm	400–700 nm (chlorophyll) 700–1100 nm (near-infrared)
Wavelength pitch	N/A	10 nm	N/A
Detectors	Silicon photodiode	Silicon photodiode array (40 dual elements)	Silicon photodiode array (8 elements)
Light sources	A red LED and an NIR LED	3 pulsed xenon lamps	An RGB LED and an NIR LED

<sup>1</sup> <http://www.adc.co.uk/wp-content/uploads/2013/09/CCM200plus.pdf> (accessed on 01.09.2016).

<sup>2</sup> [http://www.konicaminolta.com/instruments/download/catalog/color/pdf/cm2600d\\_catalog\\_eng.pdf](http://www.konicaminolta.com/instruments/download/catalog/color/pdf/cm2600d_catalog_eng.pdf) (accessed on 01.09.2016).

**Table 3.** Test statistics (one-way ANOVA).

	Sum of squares (SS)	DF	Mean square (MS)	F	P-value
Between groups	5836	9	648.4444	4.796778	0.000522
Within groups	4055.5	30	135.1833		
Total	9891.5	39			

## 6. Conclusion

Our prime design objective in this study was to design a device that would make possible repetitive, nondestructive, and rapid measurements with automatic averaging calculations of relative chlorophyll, water content, and starchiness. A simple, portable, yet comparatively improved and robust handheld instrument was developed for fruit-quality assessment. Our device determines the pigmentation, water content, and cellular structure of 12 different fruits and was successfully tested in the field where dust proved to have a negligibly minor effect on measurements. We nonetheless noticed that direct sunlight interfered with in situ analysis, so care was taken to block external illumination by artificially generating shade or by sampling at times and places when and where no direct solar radiation was received.

Our device is currently being modified to monitor reflectance and/or absorbance of different live tissues. Using additional attachments, we are working on a flexible design for reflectance and/or absorbance measurements using different tissue types and biomaterials. We hope that an improved device will allow for the study of subcutaneous tissue; tracking of the healing of injuries, surgery scars, gashes/cuts, and burns; the determination of pigmentation changes and dysplasia/neoplasia on or close to tissue surfaces.

### Acknowledgment

We are grateful to Ateş Parlar and Oğuzhan Kafalı for their invaluable support while using the Lambda 900 spectrophotometer (covering UV, Vis, and NIR wavelength ranges) in their research laboratory for our preliminary experiments.

### References

- [1] Nicolai BM, Beullens K, Bobelyn E, Peirs A, Saeys W, Theron KI, Lammertyn J. Nondestructive measurement of fruit and vegetable quality by means of NIR spectroscopy: a review. *Postharvest Biol Tec* 2007; 46: 99-118.
- [2] Abbott JA. Quality measurement of fruits and vegetables. *Postharvest Biol Tec* 1999; 15: 207-225.
- [3] Cen H, He Y. Theory and application of near infrared reflectance spectroscopy in determination of food quality. *Trends Food Sci Tech* 2007; 1: 72-83.
- [4] Lammertyn J, Nicolai BM, Ooms K, de Smedt V, de Baerdemaeker J. Non-destructive measurement of acidity, soluble solids, and firmness of Jongold apples using NIR-spectroscopy. *T ASAE* 1998; 41: 1089-1094.
- [5] Carlomagno G, Capozzo L, Attolico G, Distante A. Non-destructive grading of peaches by near-infrared spectrometry. *Infrared Phys Techn* 2004; 46: 23-29.
- [6] Sirisomboon P, Tanaka M, Jujita S, Kojima T. Evaluation of pectin constituents of Japanese pear by near infrared spectroscopy. *J Food Eng* 2007; 78: 701-707.
- [7] Galvao LS, Formaggio AR, Tisot DA. Discrimination of sugarcane varieties in Southeastern Brazil with EO-1 Hyperion data. *Remote Sens Environ* 2005; 94: 523-534.
- [8] Liu Y, Chen X, Ouyang A. Nondestructive determination of pear internal quality indices by visible and near-infrared spectrometry. *Food Sci Technol Int* 2008; 41: 1720-1725.
- [9] Jamshidi B, Minaei S, Mohajerani E, Ghassemian H. Reflectance Vis/NIR spectroscopy for nondestructive taste characterization of Valencia oranges. *Comput Electron Agr* 2012; 85: 64-69.
- [10] Peirs A, Lammertyn J, Ooms K, Nicolai BM. Prediction of the optimal picking date of different apple cultivars by means of VIS/NIR-spectroscopy. *Postharvest Biol Tec* 2001; 21: 189-199.
- [11] Cayuela JA. Vis/NIR soluble solids prediction in intact oranges (*Citrus sinensis* L.) cv. Valencia Late by reflectance. *Postharvest Biol Tec* 2008; 47: 75-80.
- [12] Moghimi A, Aghkhani MH, Sazgarnia A, Sarmad M. Vis/NIR spectroscopy and chemometrics for the prediction of soluble solids content and acidity (pH) of kiwifruit. *Biosyst Eng* 2010; 106: 295-302.
- [13] Lin H, Ying Y. Theory and application of near infrared spectroscopy in assessment of fruit quality: a review. *Sens Instrumen Food Qual* 2009; 3: 130-141.
- [14] Cortes V, Ortiz C, Aleixos N, Blasco J, Cubero S, Talens P. A new internal quality index for mango and its prediction by external visible and near-infrared reflection spectroscopy. *Postharvest Biol Tec* 2016; 118: 148-158.
- [15] Gao F, Dong Y, Xiao W, Yin B, Yan C, He S. LED-induced fluorescence spectroscopy technique for apple freshness and quality detection. *Postharvest Biol Tec* 2016; 119: 27-32.

- [16] Camps C, Christen D. Non-destructive assessment of apricot fruit quality by portable visible-near infrared spectroscopy. *Food Sci Technol-Leb* 2009; 42: 1125-1131.
- [17] Sánchez MT, De la Haba MJ, Pérez-Marín D. Internal and external quality assessment of mandarins on-tree and at harvest using a portable NIR spectrophotometer. *Comput Electron Agr* 2013; 92: 66-74.
- [18] Blakey R.J. Evaluation of avocado fruit maturity with a portable near-infrared spectrometer. *Postharvest Biol Tec* 2016; 121: 101-105.
- [19] Makky M, Soni P. In situ quality assessment of intact oil palm fresh fruit bunches using rapid portable non-contact and non-destructive approach. *J Food Eng* 2014; 120: 248-259.
- [20] Fernández-Espinosa AJ. Combining PLS regression with portable NIR spectroscopy to on-line monitor quality parameters in intact olives for determining optimal harvesting time. *Talanta* 2016; 148: 216-228.
- [21] Mansouri C, Kashou NH. New window on optical brain imaging; medical development, simulations and applications. In: Yasin M, editor. *Selected Topics on Optical Fiber Technology*. Rijeka, Croatia: InTech; 2012. pp. 271-288.