

WCES-2010

Brushless direct current (BLDC) machine Bipolar – Unipolar Driving Circuit education study

Gokhan Yan^a, N. Füsün Oyman Serteller^a *

^aMarmara University, Faculty of Technical Education, Department of Electrical Education, Kadikoy, Istanbul 34722, Turkey

Received October 22, 2009; revised December 31, 2009; accepted January 12, 2010

Abstract

Bipolar and unipolar driver circuits were designed and developed in order to control BLDC motor parameters in a laboratory environment. The characteristics of the operating parameters are mathematically and graphically presented in a trial. BLDC motor bipolar and unipolar drive features are given in detail to support students' theoretical understanding. The reason is to acquaint the students with BLDC motor bipolar and unipolar driving, especially when studying the dynamic behavior of the electrical motors from starting, during stable working to the transient operating phase. This study is also intended to obtain efficient operating parameters by using minimum electronic devices compared to other identical motor and driving circuits. The main goal is to provide students with the best practical observation and theoretical information, designing a device which is simple and easily understood.

© 2010 Elsevier Ltd. All rights reserved.

Keywords: BLDC (Brushless Direct Current Motor); Unipolar Drive; Bipolar Drive; Laboratory Experiment Set.

1. Introduction

When BLDC motors are compared to other identical or synchronous motors, their advantages are briefly sorted as follows; they are smaller in size, produce more power, operate more quietly and controlled in a wide range. Its usage is getting wider in industry. Nonetheless, a well-designed driver cycle is required to start these motors efficiently. Hence, a comprehensive analysis of the parts of the driver cycle is considerably useful for both industrial and scientific studies. A development in semi-conductor and permanent magnetic material technology has increased the usability of BLDC motor. BLDC motors are started through two kinds of driver cycles, like other small and medium-sized powerful motors: bipolar and unipolar. Some applications a bipolar driver is suggested such as loaded starting. But some application unipolar drive is needed such as high speed requirements. These circuits are quite complex and puzzling to understand electronic devices and their features. In this study simple and understandable experiment set has been developed and motor parameters have been analyzed to give the ideas to motor operation performances, control and command. In addition all the relationship of the motor parameters is given and an experiment set are realized to show all the control effects on motor. A three phase, wye-connected and sole wound

* N. Fusun Oyman Serteller. Tel.: +90-216-3365770-265 ; fax: +90-216-337-9787 .

E-mail address: fserteller@marmara.edu.tr.

BDCM was utilized and its require plate values was given in table 1 Wildi, T. (2002), Fitzgerald, A. at all (2003), Sen, P.C. (1996).

2. Bipolar- Unipolar Driven Motor Working Analysis

In the bipolar working mode; the motor is driven by the direction change of the current flowing through the phase windings in particular periods. In the Bipolar working; the current flowing through the winding groups changes direction during the commutation process depending on the rotor turn. Each phase winding is controlled by two switching elements as shown in Figure 1.

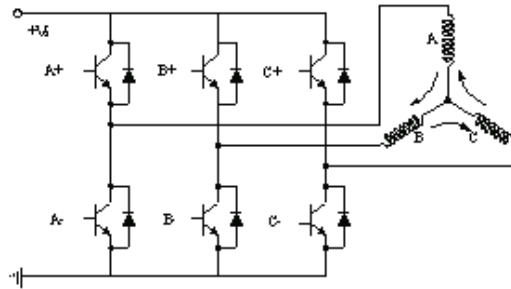

Figure 1. General scheme for bipolar drive for brushless direct current motor.

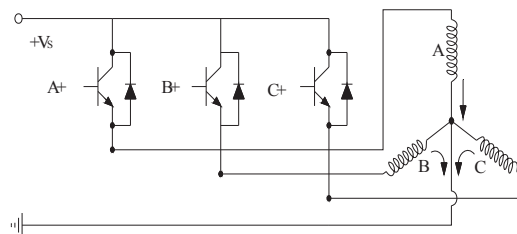

Figure 2. General schemes for unipolar drive for Brushless direct current motor.

Bipolar working causes low current draw at the time of starting. Because the torque constant and opposite emf constant is high (Fig.1). On the other hand, unipolar driving gives high speed during stable working. The needs of the elements are less; this gives advantage to it over bipolar drive. The speed of the motor with unipolar drive is higher than bipolar drive. This drive is appreciated especially for high speed ventilation system (Fig.2). However it has low starting torque.

Bipolar and unipolar drive circuits' chart can be divided in three sections generally. In the first section, a controller that processes the position information coming from the sensors is available with electronic component (MC33035). The position information processed by the controller is used to trigger the six switching element (IRF740) for the bipolar working mode and three switching (in some cases this number can be increased) that can be named as second section. The third section in the circuit consists to ensure the insulation of MOSFET drive circuit elements (IR2113) between the section that belongs to the keying elements where the high source voltage is available and the section that belongs to the controller where low voltage is available (Yan, 2009; Zhu, 2007). Terminal voltage is distributed to the motor over the switching elements determined and triggered by the controller according to the position of the rotor. Figure 3 (a) show complete part of the experiment set and figure 3 (b) shows the parts of the driving circuit.

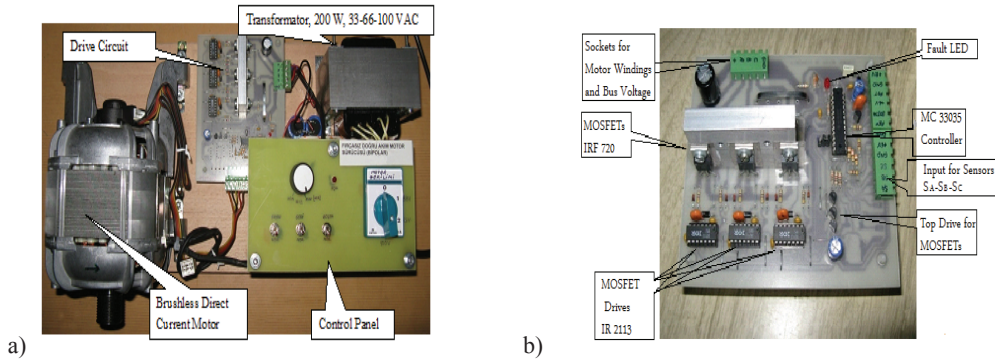

Figure 3 (a) Complete Diagram of set (motor and driving circuit) (b) Main components of the drivers circuits.

And if needed to take necessary measurement the set is built simple and portable. The motor’s necessary plate information is given in table 1.

Table 1. Motor characteristics of BLDC motor.

Working Volt.	220	V
Power	550	W
Working Current	2	A
Num.of Phases	3	-
Insulation Class	F	-
Return Direction	Clockwise/ visa verse	-
Stator	3 Phased Star con.	-
Rotor	4 Piece and 2p=4Ferrit	-
Working Volt.	220	V

When Three Phased Brushless Direct Current Motor is driven by three phase bridge circuit, due to the alternative current flowing through each winding, the throughput which is the percentage of the mechanical output power to the electrical input power is high. Optic sensors were used to sense the rotor position. Six phototransistors were laid on the layer in equal distances (Gopalarathnam, 2003; Armstrong, 2005) for bipolar driver and three transistors for unipolar driver. If we use the both driver in a BLDC motor, six transistors can be used for the circuit to operate efficiently. In parallel to these values, together with the increase in the voltage that is applied to the motor, increase in the number of turns, their torque and the current they draw was observed. When all the figures are observed briefly the first thing that the Bipolar operating shows that the current oscillations and torque vibrations are less a linear run according to unipolar drive. Unipolar drive is operated more noisily and loosely than bipolar drive (Armstrong 2005; Ellis, 1996). When the motor starts the operation it is possible the observation of the combined working with motor and driving circuit and the control it manually to understand of the whole system.

3. BLDC motor Bipolar- Unipolar operating mathematical equations and experiments results

As indicated by equations (1,2,3,4), motor speed changes proportionally in response to the source voltage applied. In a BLDC, all the equations are handled with their original modes like (1),(2),(3),(4) and calculations are performed according to these equations. However, for the bipolar mode and unipolar mode, the equations take different values in the machine for the same application voltage. For example, in unipolar drives, the conductor’s number is taken as half, and so back EMF voltage is half and the starting torque is also half at the same speed. This means that in unipolar drive it is not possible to use the whole winding features for calculation of the motor parameters (Ellis, 1996; Kim, 2005; Hall Effects Sensors, 2007).

$$E = K_f \phi n \tag{1}$$

$$M = K_M \Phi I_a \tag{2}$$

$$U = I_a R_a + E \tag{3}$$

$$M = \frac{K_M \Phi U}{R_a} - \frac{K_M K_e \Phi^2 n}{R_a} \tag{4}$$

Hence, K_M Torque constant, K_e reverse EMF constant, R_a armature resistance (Ω), n speed (turn/minute), U applied voltage (Volt), Φ magnetic flux(Weber), E reverse (back) EMF(Volt).

The mathematical equations are given in the simplest form, in order to facilitate the teaching of practical information using mathematical methods. The tests on motor by using drive circuits range of 100 V DC voltages is realized symbolically as shown in figure 4 (a) and (b), illustrating bipolar and unipolar drive respectively. After the BLDC motor has reached the highest speed under no load condition, load torque is increased regularly. Torque and speed are than measured by the torque meter, and the current is measured by the current probe. The results are shown in fig.5 and 6. This graphical representation helps the students to understand the effect of the drive circuits on the motor. This graphical result allows the students to have idea effect the drive circuits on the motor parameters.

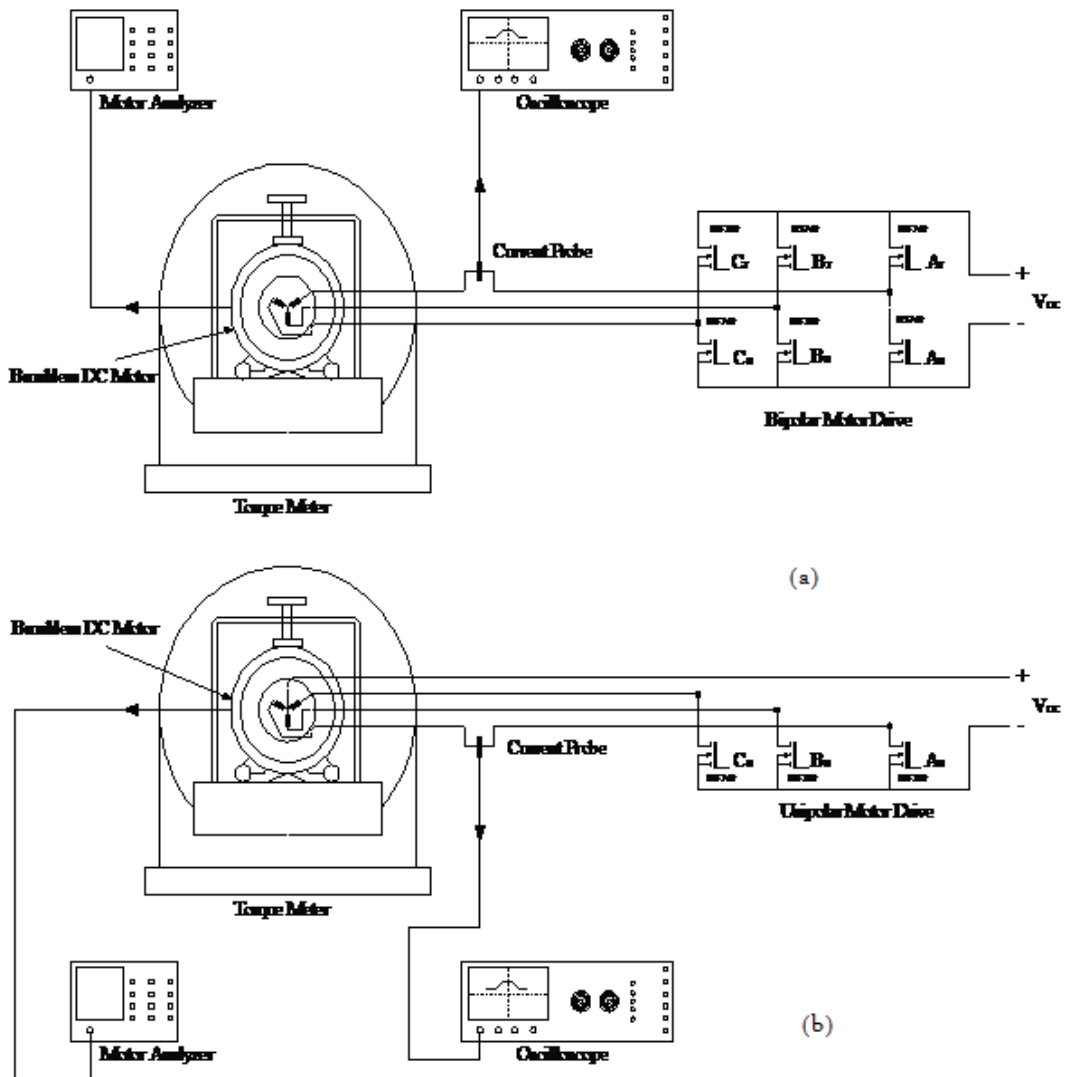

Figure 4. Total test scheme for designed bipolar driving circuit (a) Bipolar driver circuit (b) Unipolar driver circuit.

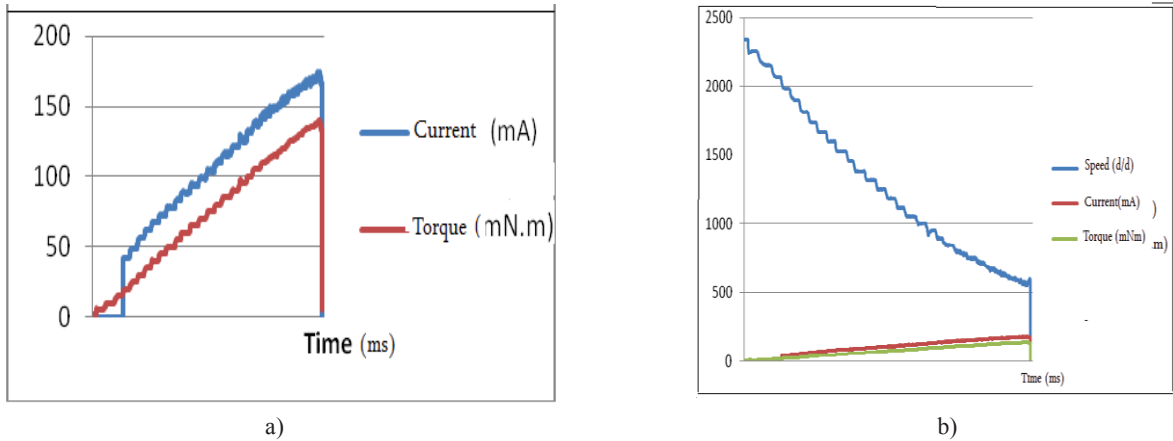

Figure 5. (a)Bipolar drive operating current, torque (b) speed, torque and current relationship.

Figure 5(a) and 6(a) indicate that an increase torque causes increase in current in bipolar and unipolar mode respectively. However when the torque increases, current ripple increases very rapidly, the rippling side of the current graphic can be analyzed separately by wavelet methods. The current rippling is very sharp and reduction of torque constant is bigger than bipolar drive (fig.5 (a)-fig 6(a)). This causes the unipolar drive to be more unbalanced than the bipolar drive.

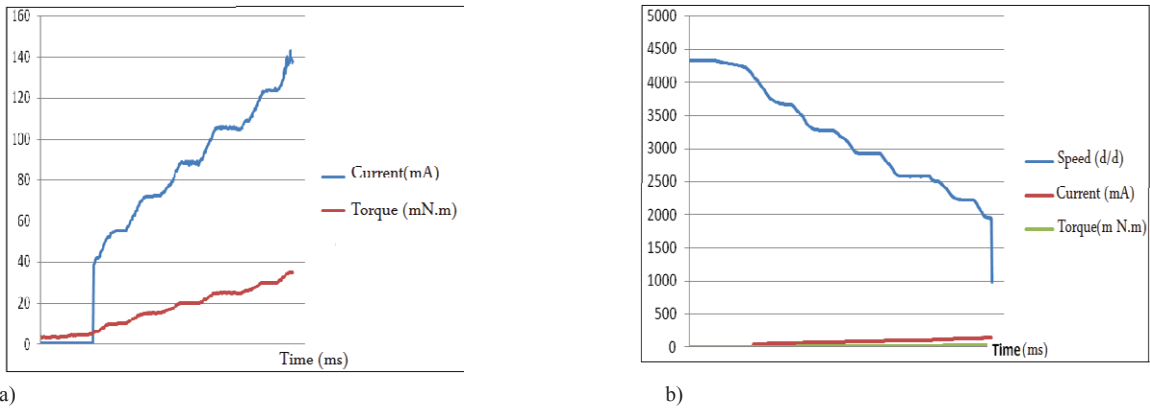

Figure 6. (a) Unipolar drive operating current, torque, (b) Speed, torque and current relationship.

Figures 5(b) and 6(b) show the relationship between currents and torque, the torque increases while the value of the current is increasing. Because of this, current and torque increases too fast. In unipolar mode the motor speed is clearly higher than in bipolar mode. This graphical presentation helps students to understand the effect of the drive circuits on the motor parameters.

This paper show that each type of drive has some advantages, and that both cases can be used in the same application to utilize useful features of each mode. In other words, a BLDC motor may be configured so that it starts in bipolar mode and then operates in unipolar mode, so that it takes advantage of the characteristics of both operating conditions.

4. Conclusion

BLDC motors are highly efficient, reliable motors, and operate quietly. They are conveniently utilized in applications entailing variable motor speed and high starting torque, through switching or pulse width modulation (PWM). A study was performed on BLDCs on account of these characteristics. Since the BLDC motor has a permanent rotor structure, two types of main drive circuit (bipolar and unipolar) are presented in a simple and easily understood style. In presenting the required theoretical information, the study tried to provide clear, concise explanation and, where possible, to minimize reliance on mathematical

equations. The accompanying illustrations also convey to the students the machine's starting and operating condition, to assist their understanding of how things work in real-world applications.

Acknowledgment

This study is the part of a master science project and it is supported and promoted by Marmara University Bakko institution.

References

- Wildi, T. (2002). *Direct Current Motors, Electrical Machines Drives and Power Systems*, 5th Edition. , Laval University, Canada.
- Fitzgerald, A., Kingsley, C. & Umans, S.D. (2003). *Permanent Magnet DC Machines , Electric Machinery*, 6th Edition, Cambridge, United States.
- Sen, P.C. (1996). *Permanent Magnet” , Principles Of Electrical Machinery and Power Electronics*, Queens University, Canada.
- Yan G. (2009). *Brushless DC Motors Analysis and Driving System Design*, MSc. Thesis, Marmara University ,Institute for Graduate Studies in Pure Science and Applied Sciences, İstanbul, Turkey.
- Zhu, J.,G. (2007). *Brushless DC Motor*, Electromechanical Systems.
- Gopalarathnam, T. & Toliyat, H.A. (2003). *A New Topology For Unipolar Brushless DC Motor Drive With High Power Factor*, IEEE Transactions On Power Electronics.
- Armstrong, L. (2005). *Current Control Removes Brushless DC Motor Commutation Spikes*, Zetex Semiconductors plc.
- Ellis, G. (1996). *Advances in Brushless DC Motor Technology Control and Manufacture*, Kollmorgen Corporation , published PCIM-Europe.
- Kim, C.G., Lee, J.H., Kim, W. & Youn, J.M. (2005). *Study On Maximum Torque Generation For Sensorless Controlled Brushless DC Motor With Trapezoidal Back EMF*, IEEE Proc.-Electr. Power Applications.
- Hall Effects Sensors*, (2007) Honeywell Micro Switch Sensing and Control.